

# ISO TECH



## User Manual

Applies to:

Software version 1.4.16+

Firmware version 3.17+

Isothermal Technology Limited  
Pine Grove  
Southport  
Merseyside  
PR9 9AG  
T: +44 (0)1704 543830  
F: +44 (0)1701 544799  
E: [info@microk.co.uk](mailto:info@microk.co.uk)  
W: [www.microk.co.uk](http://www.microk.co.uk)

## CONTENTS

<b>1</b>	<b>INTRODUCTION .....</b>	<b>6</b>
1.1	Unpacking.....	7
1.2	Safety .....	7
1.3	Powering Up Your microK .....	9
1.4	A Quick Tour of Your microK .....	9
<b>2</b>	<b>MAKING A MEASUREMENT (TUTORIALS).....</b>	<b>12</b>
2.1	Measuring Temperature with a Calibrated SPRT.....	12
2.2	Measuring Temperature with a Thermocouple .....	16
<b>3</b>	<b>DRIVING YOUR MICROK.....</b>	<b>20</b>
3.1	Introduction.....	20
3.2	The Startup Window .....	20
3.3	The Main Window .....	21
3.4	The Single Tab.....	22
3.5	The Multi Tab .....	25
3.6	The Settings Tab .....	26
3.7	The Instrument Tab.....	31
3.7.1	Edit Thermometers.....	31
3.7.2	Edit Resistors .....	34
3.7.3	Calibration .....	35
3.7.4	Restart Software.....	35
3.7.5	Update Software.....	36
3.7.6	Change Password .....	36
3.7.7	Port Settings.....	37
3.7.8	Set Date and Time.....	38
3.7.9	Backup Data.....	38
3.7.10	Clear Data Files.....	39
3.7.11	Backup Configuration .....	39
3.7.12	Load Configuration .....	39
3.8	Using the Thermometer Database .....	40
3.9	Using the Reference Resistors Database .....	41
3.10	Saving Instrument Configurations .....	41
3.11	Password Protection of Key Settings .....	42

<b>4</b>	<b>CONNECTING THERMOMETER SENSORS .....</b>	<b>43</b>
4.1	The “Cable-Pod” Connectors .....	43
4.2	Connecting PRTs (4-wire).....	43
4.3	Connecting PRTs (3-wire).....	44
4.4	Connecting PRTs (2-wire).....	44
4.5	Connecting Thermocouples (external Ice Point or WTP).....	45
4.6	Connecting Thermocouples (using RJ compensation) .....	46
4.7	Connecting Thermistors.....	46
<b>5</b>	<b>GOOD PRACTICE GUIDELINES.....</b>	<b>48</b>
5.1	Looking After Your microK .....	48
5.2	Making a Good Electrical Measurement .....	48
<b>6</b>	<b>THE MICROK TECHNOLOGY.....</b>	<b>51</b>
6.1	The ADC.....	51
6.2	Substitution Topology .....	53
6.3	Minimising Thermal EMFs .....	55
6.4	Solid-State Switching.....	56
6.5	Inherent Stability .....	56
6.6	Eliminating Self-Heating Effects.....	57
<b>7</b>	<b>CALIBRATION.....</b>	<b>58</b>
7.1	Checking Calibration .....	58
7.1.1	Checking the Master Current Source.....	58
7.1.2	Resistance Measurements .....	59
7.1.2.1	Zero Ohms Check .....	59
7.1.2.2	400 $\Omega$ Internal Reference Resistor.....	60
7.1.2.3	100 $\Omega$ Internal Reference Resistor.....	61
7.1.2.4	25 $\Omega$ Internal Reference Resistor .....	61
7.1.2.5	10 $\Omega$ Internal Reference Resistor .....	61
7.1.2.6	1 $\Omega$ Internal Reference Resistor .....	61
7.1.3	Voltage Measurements .....	62
7.1.3.1	Zero Voltage Offsets.....	62
7.1.3.2	Voltage Span Check.....	62
7.2	Adjusting Calibration.....	63
7.2.1	Calibrate Master Current Source.....	64
7.2.2	Calibrating the 400 $\Omega$ Internal Reference Resistor .....	65

7.2.3	Calibrating the 100 $\Omega$ Internal Reference Resistor.....	66
7.2.4	Calibrating the 25 $\Omega$ Internal Reference Resistor.....	66
7.2.5	Calibrating the 10 $\Omega$ Internal Reference Resistor.....	66
7.2.6	Calibrating the 1 $\Omega$ Internal Reference Resistor.....	66
7.2.7	Calibrating Voltage Zeros .....	67
7.2.8	Calibrating Voltage Span .....	68
<b>8</b>	<b>RS232 INTERFACE .....</b>	<b>70</b>
8.1	Establishing an RS232 Connection.....	70
<b>9</b>	<b>GPIB.....</b>	<b>73</b>
9.1	GPIB Address.....	74
9.2	Establishing a GPIB Connection .....	74
<b>10</b>	<b>SCPI COMMAND SET .....</b>	<b>75</b>
10.1	Command Terminators .....	75
10.2	SCPI Command Structure .....	75
10.2.1	SCPI Numeric Suffices.....	77
10.2.2	Parameters.....	77
10.2.3	Units .....	77
10.3	Making Measurements using SCPI Commands.....	79
10.3.1	Measuring Resistance using SCPI Commands .....	79
10.3.2	Measuring Voltage using SCPI Commands .....	80
10.4	SCPI Commands .....	81
10.4.1	Command: *IDN? .....	82
10.4.2	Command: *RST.....	82
10.4.3	Command: SENSE:FUNCTION .....	82
10.4.4	Command: SENSE:FUNCTION? .....	82
10.4.5	Command: SENSE:CHANnel.....	83
10.4.6	Command: SENSE:CHANnel? .....	83
10.4.7	Command: SENSE:VOLTage:RANGe .....	83
10.4.8	Command: SENSE:VOLTage:RANGe? .....	84
10.4.9	Command: SENSE:FRESistance:REFerence .....	84
10.4.10	Command: SENSE:FRESistance:REFerence?.....	84
10.4.11	Command: SENSE:FRESistance:RANGe.....	84
10.4.12	Command: SENSE:FRESistance:RANGe? .....	85
10.4.13	Command: SENSE:RATio:REFerence.....	85
10.4.14	Command: SENSE:RATio:REFerence? .....	85
10.4.15	Command: SENSE:RATio:RANGe .....	86
10.4.16	Command: SENSE:RATio:RANGe? .....	86
10.4.17	Command: INITiate .....	87
10.4.18	Command: FETCh?.....	87
10.4.19	Command: READ? .....	87
10.4.20	Command: READ#? .....	87

10.4.21	Command: MEASure:VOLTage?	88
10.4.22	Command: MEASure:FRES:REF?	88
10.4.23	Command: MEASure:RAT:REF?	89
10.4.24	Command: CURRent	89
10.4.25	Command: TEST:CURRent	90
10.4.26	Command: CALibrate:CURRent	90
10.4.27	Command: CALibrate:REFerence	90
10.4.28	Command: CALibrate:REFerence?	90
10.4.29	Command: CALibrate:OFFSet	91
10.4.30	Command: CALibrate:OFFSet?	91
10.4.31	Command: CALibrate:GAIN	91
10.4.32	Command: CALibrate:GAIN?	92
10.4.33	Command: CALibrate:PASSword	92
10.4.34	Command: CALibrate:UNLock	92
10.4.35	Command: CALibrate:LOCK	93
<b>11</b>	<b>SPECIFICATION</b>	<b>94</b>
<b>12</b>	<b>APPROVALS</b>	<b>96</b>
12.1	CE Declaration	96
12.2	FCC Statement	96
12.3	Standards Applied	97

# 1 Introduction

The microK-400 and micro-800 are the only precision thermometry instruments that can achieve sub mK precision and will work with all three common thermometer sensors (PRTs, Thermocouples and Thermistors). They are based on a completely new measurement technology, unique to these products, that provides better accuracy and lower noise than comparables technologies (see section 6). They are also the first instruments of their type to be completely solid-state, making them highly reliable.

Despite their sophistication, these instruments are very easy to use. There are no knobs and dials, just a colour touch screen that makes use of the familiar Windows CE™ operating system. If you use a Windows™ operating system on your PC, you will find these instruments intuitive and easy to use. The USB port on the front panel allows you to plug in and use other devices that work with Windows CE™ such as a mouse, keyboard or flash drive.

Readings can be displayed in resistance ratio, ohms, volts or temperature units (°C, °F or K). Algorithms for conversion to temperature include:

PRTs:	ITS-90 Callendar-Van Dusen (IEC751 or custom coefficients)
Thermocouples:	IEC584-1 (for type B, E, J, K, N, R, S, T) Type L polynomial Gold Platinum Reference Function Polynomial
Thermistor:	Steinhart-Hart

This manual provides a comprehensive guide to using the instrument. We recognise that you will probably not wish to read it through at this time so suggest you read the safety section below, take one of the tutorials in section 2

and then refer back to the manual using the list of contents to find additional information as required.

## **1.1 Unpacking**

Your microK product should comprise the following items:

- ⌘ microK precision thermometer
- ⌘ power lead suitable for your country
- ⌘ this user manual

If any item is missing or damaged, please report this immediately to your supplier. If possible, we recommend that you retain the packaging material in case you need to return the instrument for calibration or service since it has been designed to ensure that your microK is properly protected during transportation.

## **1.2 Safety**

The microK is a precision instrument, designed for use in a laboratory. It complies with the requirements of safety standard EN61010-1 (2001) and is therefore safe to use in laboratory or light industrial environments. It is not intended for use outdoors or in extreme environments (refer to specification in Section 11).



The microK is likely to be connected to thermometer sensors in use and the operator should take care to ensure that the complete system is safe. For example, metal sheathed thermometers may be connected to the microK and then placed in a furnace powered from a 230V electrical supply. Single fault conditions in such a furnace could lead to the thermometer wires and therefore the front terminals of the microK becoming electrically live and therefore a hazard to the operator. Suitable precautions should be taken, such as using an isolating transformer in the supply to such a furnace. If you require further advice on safety issues, please contact Isothermal Technology or one of our appointed distributors - we have extensive experience of thermometry and can provide advice and equipment to help you.

Retain these instructions. Use only as specified in these operating instructions or the intrinsic protection may be impaired.

Please observe the following safety precautions:

- ⚠ Do not use your microK if it is damaged
- ⚠ Only connect to an earthed supply socket. **THIS UNIT IS CLASS 1 CONSTRUCTION AND MUST BE EARTHED!**
- ⚠ Connect only to a power supply with a voltage corresponding to that on the rating plate
- ⚠ This equipment is for indoor use and will meet its performance figures within an ambient temperature range of 5°C to 40°C with maximum relative humidity of 80% for temperatures up to 31°C decreasing linearly to 50% RH at 40°C
- ⚠ Equipment is for operation at installation category II (transient voltages) and pollution degree II in accordance with IEC 664 at altitudes up to 2000 metres
- ⚠ Before replacing a fuse, **DISCONNECT THE EQUIPMENT FROM THE ELECTRICAL SUPPLY**
- ⚠ The fuse is contained in the IEC socket on the rear panel. It must only be replaced with a fuse of the type and rating marked on the rear panel
- ⚠ If a replacement fuse fails immediately, contact your local service agent. **DO NOT** replace with a higher value
- ⚠ Always use the power cord supplied. Your sales outlet can provide a lead suitable for your country
- ⚠ This equipment is for use in moderate climates only. **NEVER** use the equipment in damp or wet conditions
- ⚠ Avoid excessive heat, humidity, dust & vibration
- ⚠ Do not place liquid filled containers on the equipment
- ⚠ Do not use where the equipment (or any associated accessories) may be subjected to dripping or splashing liquids
- ⚠ Ensure that the power switch is easily accessible to allow the unit to be switched off
- ⚠ The equipment weighs 13kg; use the handles provided. Always disconnect the equipment from the electrical supply and any ancillary units before moving
- ⚠ Ensure that tabletop equipment is placed on a solid, level surface, which is able to support its weight (and that of any attached accessories)
- ⚠ Ensure all cables and wires are routed safely to avoid tripping; also to avoid sharp bends and pinches
- ⚠ Clean only with a damp cloth. Do not wet or allow moisture to penetrate the unit. Do not use solvents. See section 5.1 for details of cleaning procedure
- ⚠ The product should be subjected to regular in-service inspections as required by local regulations; a yearly interval is suggested
- ⚠ Verify that the supply cordset is undamaged and that the enclosure is bonded to protective earth. Do not apply earth test currents to any front panel terminal nor to the shrouds of the USB, RS232 or GPIB connectors

- ⚠ The product is designed to comply with EN 61010-1 and can be flash tested. It is fitted with radio frequency interference suppressors. Therefore it is recommended that only a D.C. test be performed. Performing flash tests repeatedly can damage insulation
- ⚠ This equipment contains no user-serviceable parts. Refer all repairs to qualified service personnel. Contact Isothermal Technology or one of our appointed distributors for details of approved service outlets

### **1.3 Powering Up Your microK**

The microK operates on any standard AC electrical supply (88-264V RMS at 47-63Hz) so unless your supply is unusual you can simply use the power cord provided to connect your microK to a suitable electrical outlet.

The power switch is located at the rear of the instrument, immediately below the IEC connector. When you turn your microK on it will go through a standard Windows CE™ boot sequence and then display a Window containing the *Resume* button. Pressing *Resume* restarts the microK in the configuration it was in prior to the last power down, you will then see the Main Window and be ready to operate your instrument.



Before pressing the *Resume* button, make sure that any thermometers attached will not be damaged by the sense currents that will be applied (the last values used). If there is a problem, disconnect your sensors before proceeding and then reconnect them after changing the sense current to the required values.

### **1.4 A Quick Tour of Your microK**

On the front panel of your microK you will find the input terminals for the three measurement channels, the touch screen/colour display and a USB connector:

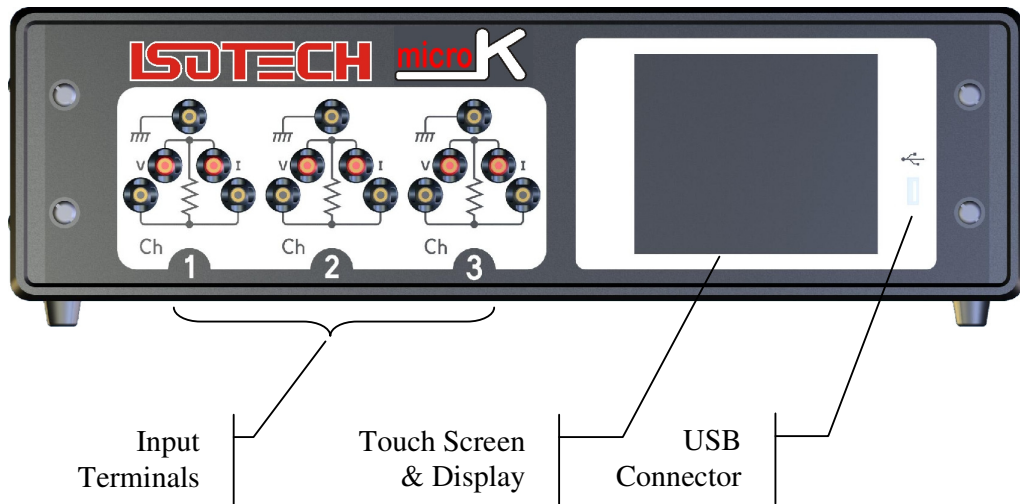

**Input Terminals:** The input terminals accept 4mm plugs, spades or bare wires. The current (I) and voltage sense (V) terminals are spaced on  $\frac{3}{4}$ " centres so that standard BNC to 4mm adaptors (not supplied) can be used to connect to thermometer sensors that have BNC terminations.

The contact material for the connectors is gold plated tellurium-copper, offering extremely low thermal EMFs when connected to copper wires/connectors. This is essential when using precision thermocouples.

**Display:** The display is a colour TFT VGA (640 x 480) LCD with a long-life CCFL (cold-cathode fluorescent lamp) backlight. A touch panel is mounted in front of the display so that you can control the instrument by simply touching the buttons displayed on the LCD. The touch panel is an industrial grade components offering good durability. It is intended to be operated with a finger. A stylus intended for PDAs may also be used – never use a sharp object with the touch panel as this will lead to premature failure.

**The USB Connector:** The USB connector is primarily intended to allow you to connect a USB flash drive, store measurement results and transfer these to a PC. The flash drive may also be used to backup the databases of thermometers, reference resistors and instrument configurations for your microK.

Other USB devices such as a mouse, keyboard, keypad or USB hub may be connected to the USB port and used, provided they utilise the standard class drivers provided with the Windows CE™ operating system incorporated in your microK.

On the rear panel of your microK you will find the electrical supply connector/power switch/fuse module plus the interface connectors that allow you to connect your instrument to a PC. The RS232 and GPIB ports allow you to control the instrument and take measurements from a PC with your own software (see section 8). The command protocol employs the widely used SCPI format (see section 9 for details). The USB connector is provided for future expansion and should not be used on this model.

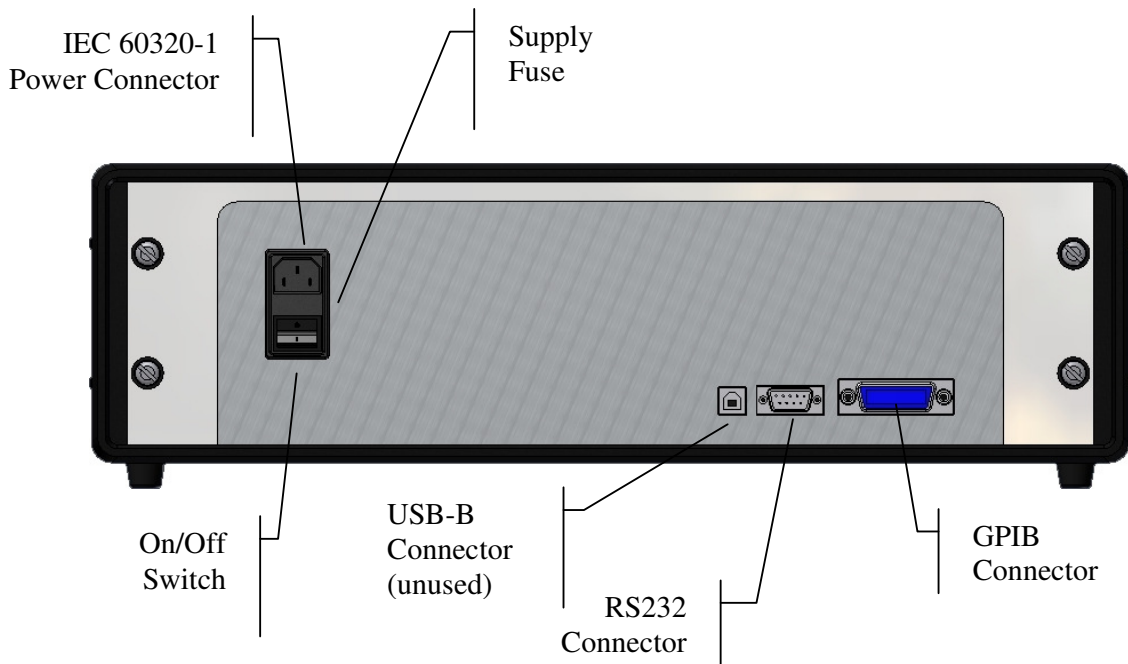

## 2 Making a Measurement (Tutorials)

The operator interface is powered by the Windows CE™ operating system. With the widespread use of Windows applications on PCs, driving your microK should be fairly intuitive. As with most Windows™ applications, it is possible to navigate your way through a process using a number of different paths, so rather than describe each window and the function of each button and then leaving you to work out how to operate the instrument, we provide you with a number of tutorials that illustrate common applications. Even if these do not describe your application, it is worth working through one of them since it will provide you with a broad understanding of the wide range of features available on your microK.

A traditional description of the function of all the features provided by the operator interface is given in section 3.

### 2.1 Measuring Temperature with a Calibrated SPRT

From startup, press *Resume* to restart your microK:

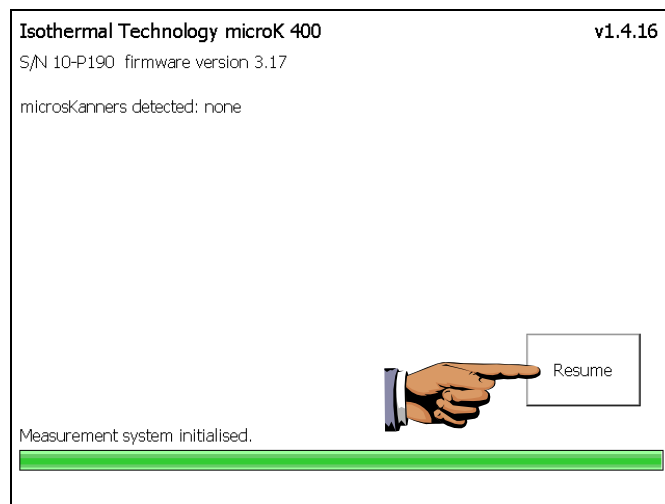

Before making any measurement, you will have to enter information about the thermometer into the microK's database. When the main window opens, press the *Instrument* tab:

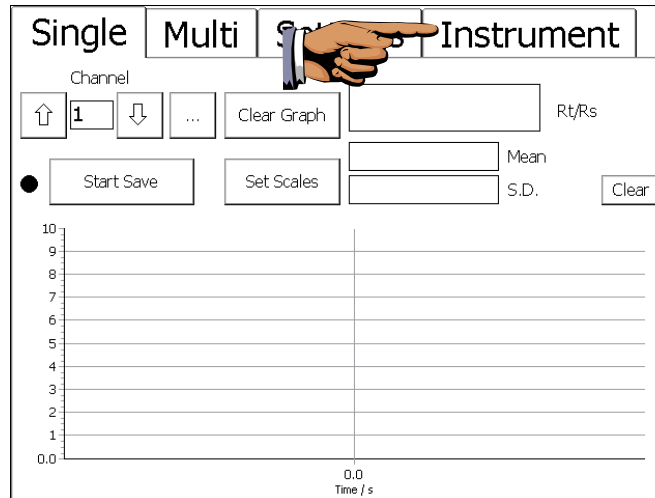

In the *Instrument* tab, press *Edit Thermometers*:

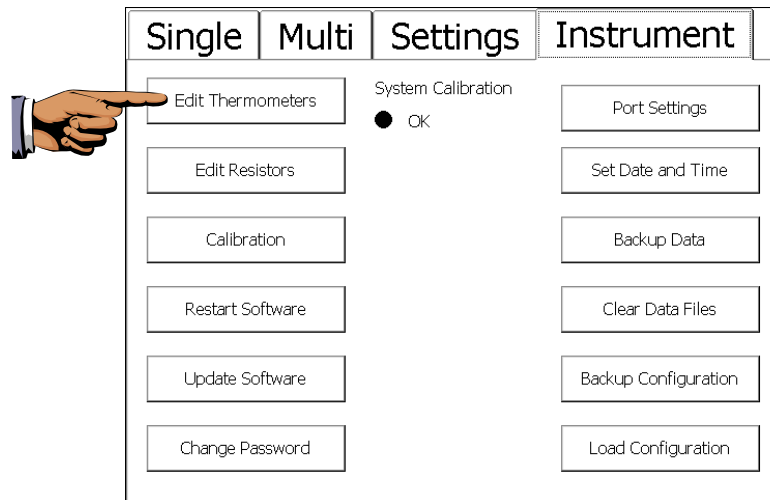

You will be prompted to enter the password (set to “1234” initially, but this should be changed before using the microK in a real measurement/calibration application to ensure security – see section 3.7.6). Enter the password to open the thermometer database window. Press *New* to create a new thermometer entry in the database and enter data by pressing the up/down or ellipses buttons by each field:

↑	SPRT1	↓	Thermometer
Thermometer Name		Thermometer Type	
SPRT1	...	↑	PRT
Manufacturer's Name		Min Temperature / °C	
Isothermal Technology	...	0.00	
Serial Number		Max Temperature / °C	
66032_123	...	660.00	
Calibration Due		Conversion	
15/12/2010	...	↑	ITS90
New	Delete	Coefficients	
OK			

Press *Coefficients* to open the coefficients window. Press the ellipses buttons to enter the calibration data for the thermometer from its calibration certificate:

Conversion Name		Conversion Type	
ITS90	...	ITS-90	
R(0.01)	25.4321	...	
Coefficients for T < 0.01°C		Coefficients for T > 0.01°C	
a	0	a	-0.00029667298
b	0	b	-2.3806071e-05
		c	3.0497121e-06
		d	0
OK		W660.323	0

Press *OK* to close the coefficients window and press *OK* again to close the thermometer database window.

Press the *Settings* tab in the main window and disable channels 2 and 3 (this will speed up measurements on channel 1, which we will be using) by using the up/down buttons by the *Channel* box to select these channels and pressing *Disable*. Use the up/down buttons to return to channel 1. Use the up/down (or ellipses) buttons by each box to select the required settings:

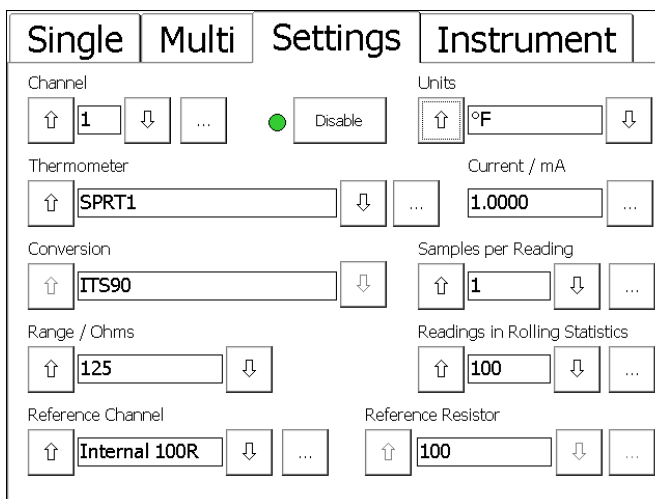

The sense current is assumed to be 1mA in this tutorial. It can be set to other values using the ellipses button by the *Current mA* box (see section 3.6).

Connect the SPRT to channel 1 (see section 4.2 for details on how to connect 4-wire PRTs). The tutorial assumes you are using the internal 100Ω reference resistor. To use an external reference resistor, first enter information on the resistor into the microK's database (see section 3.7.2), then in the *Settings* tab select the channel to which the reference is connected in the *Reference Channel* box and the reference resistor entry in the *Reference Resistor* box.

Press the *Single* tab to see the measurements in numeric and graphical form. Set the graph scales manually by making a note of the current *Mean* value and pressing *Set Scales*. This opens the graph scales window. Ensure that autoscaling is turned off (press *Autoscale* to toggle autoscaling on/off, the status of autoscaling is shown by the adjacent indicator). Use the ellipses buttons to set the y-axis limits to be 0.005°C above and below the current mean value. Use the radio and up/down buttons to set the x-axis to 5 minutes:

Y-Axis		X-Axis	
Channel	Scale / Minutes		
<input type="button" value="↑"/> 1 <input type="button" value="↓"/>	<input type="button" value="↑"/> 5 <input type="button" value="↓"/> ...		
Minimum	Time Units		
-4.259 ...	<input type="radio"/> Seconds		
Maximum	<input checked="" type="radio"/> Minutes		
-4.249 ...			
<input checked="" type="radio"/> Autoscale			
		<input type="button" value="OK"/>	<input type="button" value="Cancel"/>

Press **OK** to return to the main window. The measurement system will now accumulate data and after 5 minutes the graph will begin to scroll to show the last 5 minutes of data:

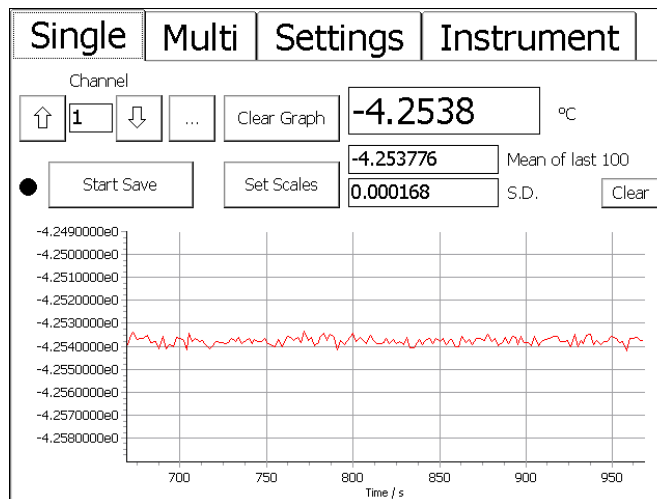

## 2.2 Measuring Temperature with a Thermocouple

From startup, press **Resume** to restart your microK:

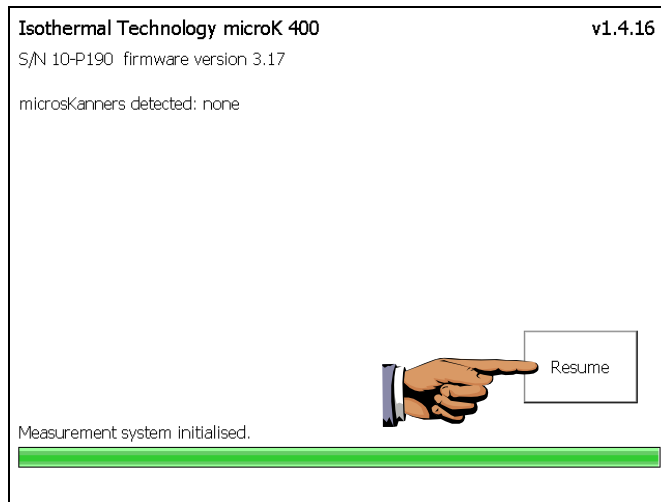

This tutorial describes the use of an uncalibrated type-N thermocouple. The microK can be used with calibrated thermocouples, in which case you will need to enter information about the thermometer into the microK's database and (see section 3.7.1) and select this thermometer entry from the *Thermometer* box in the *Settings* tab (see later in this tutorial). When the main window opens, press the *Settings* tab:

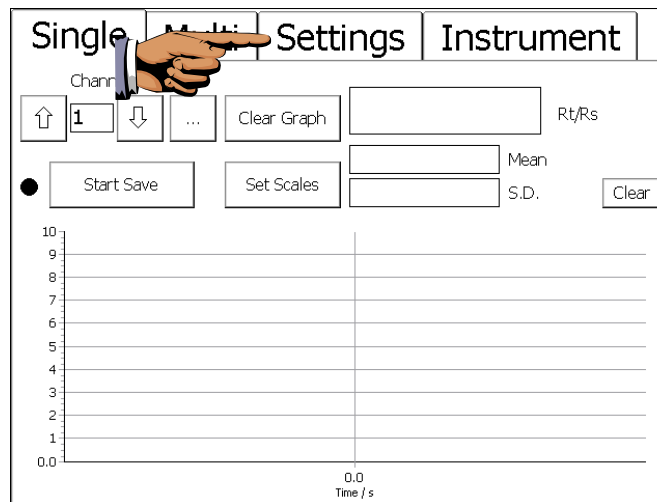

In the *Settings* tab disable channels 2 and 3 (this will speed up measurements on channel 1, which we will be using) by using the up/down buttons by the *Channel* box to select these channels and pressing *Disable*. Use the up/down buttons to return to channel 1. Use the up/down buttons by each box to select the required settings:

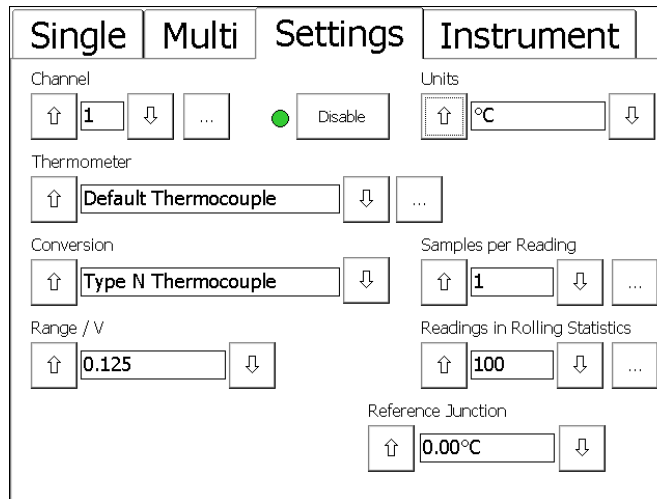

The reference junction is assumed to be an ice point in this tutorial. It can be set to the water triple-point or to use a temperature measured by one of the other channels (see sections 3.6 and 4.6) if using reference junction compensation.

Connect the N-type thermocouple to channel 1 (see section 4.5 for details on how to connect thermocouples). Press the *Single* tab to see the measurements in numeric and graphical form. Set the graph scales manually by making a note of the current *Mean* value and pressing *Set Scales*. This opens the graph scales window. Ensure that autoscaling is turned off (press *Autoscale* to toggle autoscaling on/off, the status of autoscaling is shown by the adjacent indicator). Use the ellipses buttons to set the y-axis limits to be 0.01°C above and below the current mean value. Use the radio and up/down buttons to set the x-axis to 5 minutes:

Y-Axis		X-Axis	
Channel		Scale / Minutes	
<input type="button" value="↑"/>	<input type="text" value="1"/>	<input type="button" value="↑"/>	<input type="text" value="5"/>
<input type="button" value="↓"/>	<input type="button" value="..."/>	<input type="button" value="↓"/>	<input type="button" value="..."/>
Minimum		Time Units	
<input type="text" value="0.018"/>	<input type="button" value="..."/>	<input type="radio"/> Seconds	
Maximum		<input checked="" type="radio"/> Minutes	
<input type="text" value="0.038"/>	<input type="button" value="..."/>		
<input checked="" type="radio"/> Autoscale			
		<input type="button" value="OK"/>	<input type="button" value="Cancel"/>

Press **OK** to return to the main window. The measurement system will now accumulate data and after 5 minutes the graph will begin to scroll to show the last 5 minutes of data:

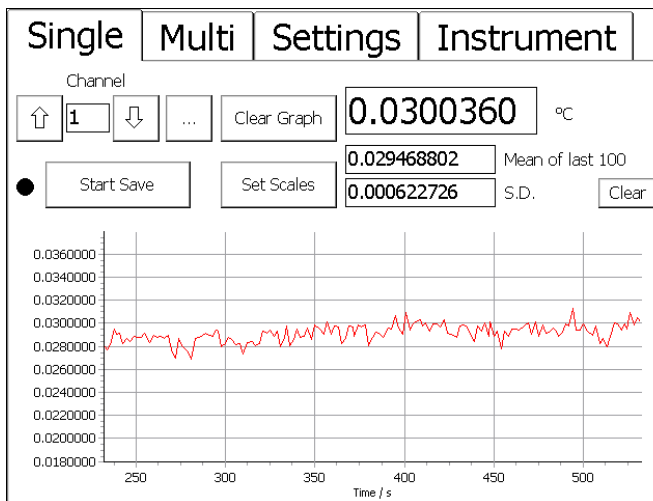

## **3 Driving Your microK**

### ***3.1 Introduction***

The operator interface for the microK is provided through the touch screen and colour display. The software is written in Microsoft's new C# language and runs under the Windows CE™ operating system. This provides a familiar and easy to use interface.

The buttons in the microK software have been sized and positioned to allow you to operate the instrument with your finger. If numeric or alphanumeric data needs to be entered, a 'soft' keyboard window appears. If you are unfamiliar with touch screen devices such as PDAs, you may initially feel that the touch screen interface is slow compared with using a mouse and keyboard, but with a little practice you should quickly become comfortable with the technology and appreciate its benefits. However, if you prefer to use a USB mouse or keyboard, you can simply plug these into the USB connector on the front panel. They will immediately become active provided they use the standard class drivers built into the Windows CE™ operating system used in the microK. To use more than one USB device, simply plug a USB hub into the front panel connector.

Calibration data entered into the microK's database is password protected and includes recalibration dates (the microK will alert you if you try to use a thermometer or reference resistor after its recalibration date). This feature ensures the integrity of your measurements and helps you to comply with the requirements of accreditation bodies.

### ***3.2 The Startup Window***

When power is applied to the microK, it goes through a Windows CE™ boot sequence that loads the operating system and then starts the microK application. The Startup Window then appears showing the microK's model and serial number together with the version numbers for the measurement system firmware and microK software used. The window also lists the details of any

“microKanner” multiplexers connected to the microK (the microKanner manual describes how to use “microKanner” multiplexers with your microK bridge). The Startup Window contains the [Resume](#) button:

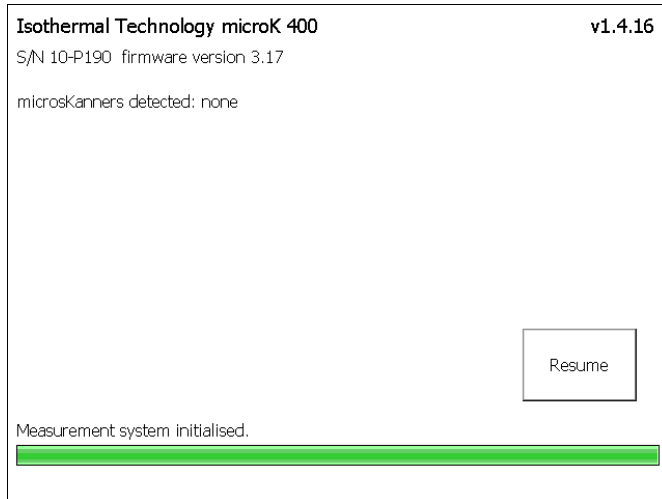

**Resume:** Pressing the [Resume](#) button places the microK in the state it was in prior to its last power down. Before pressing [Resume](#), make sure that any thermometers attached will not be damaged by the sense currents that will be applied (the last values used). If there is a problem, disconnect your sensors before proceeding and then reconnect them after changing the sense current to the required values.

### ***3.3 The Main Window***

Having pressed [Resume](#) in the Startup Window, the user is presented with the Main Window.

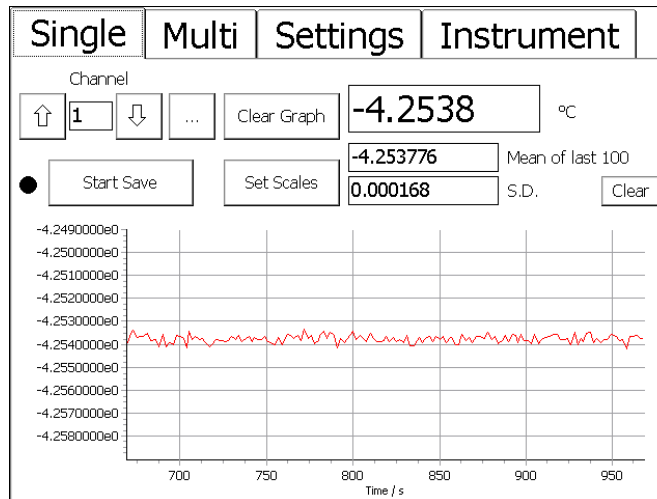

All functions to control the microK are available in this Window, which is divided into four tabs:

- Single*** displays a single channel in numeric and graphical form
- Multi*** displays all three channels in numeric form
- Settings*** allows you to configure the channels to perform the required measurement
- Instrument*** allows you to enter information on the thermometers and reference resistors used with the instrument into its database. It also allows you to save/load measurement data and instrument configurations in the database and to change instrument settings such as the GPIB address, time/date and security passwords

The Main Window opens with the *Single* tab selected.

### ***3.4 The Single Tab***

Select this tab to see a single channel in both numeric and graphical form:

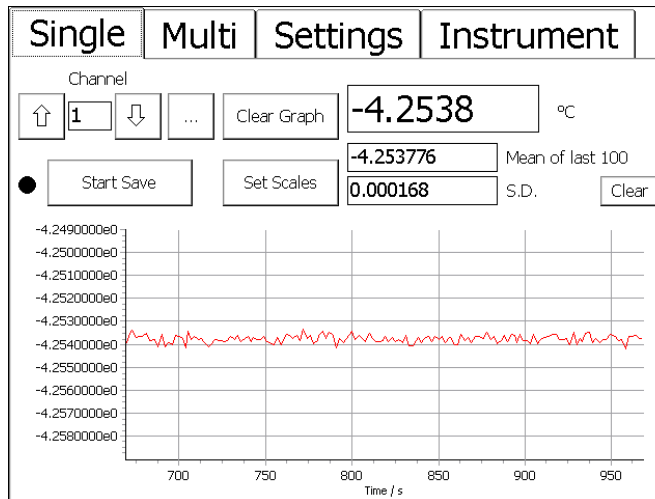

**Channel box:** Use the up/down buttons by the *Channel* box to select the channel you wish to view. Alternatively press the ellipses button to open a numeric entry window and select the channel directly. The ellipses button is particularly useful when the microK is used with microsKanner multiplexers, which can provide up to 90 expansion channels. You can only view channels that are enabled, so if a channel is disabled in the *Settings* tab it will not appear in the sequence and will not be measured. This means that the up/down buttons have no effect if only one channel is enabled.

The numeric display shows the last reading together with the mean and standard deviation of the most recent of readings (the number of readings in the statistics is set in the *Settings* tab).

**Clear Graph:** Press the *Clear Graph* button to clear the graph and re-start the autoscaling feature. This can be used to eliminate the effect of a large transient result (perhaps caused when changing connections to the thermometer) on the autoscaling function.

**Clear button:** Press the *Clear* button to clear (reset) the statistics.

**Set Scales button:** Use the *Set Scales* button to open a new window and set the x and y axes for the graphical output:

The image shows a configuration window with two main sections: Y-Axis and X-Axis. The Y-Axis section has a 'Channel' selector with up/down arrows and a box containing '1', a 'Minimum' input box with '0' and an ellipsis button, a 'Maximum' input box with '10' and an ellipsis button, and an 'Autoscale' button with a green indicator dot. The X-Axis section has a 'Scale / Seconds' selector with up/down arrows and a box containing '60', an ellipsis button, 'Time Units' with radio buttons for 'Seconds' (selected) and 'Minutes', and 'OK' and 'Cancel' buttons at the bottom right.

In this window, use the up/down buttons by the *Channel* box to select the channel whose scales you wish to change (the window opens with the currently displayed channel selected). Use the radio buttons to select either *Seconds* or *Minutes* as the units. Use the up/down buttons by the *Scale / Seconds* box to change the x-axis (time) scale (the same x axis scale is used for all channels). Or, press the ellipses button to open a Numeric Keypad window and enter the required scale directly. Any value between 1 second and 1000 minutes (inclusive) may be used.

Use the ellipses by the *Minimum* and *Maximum* boxes to open a Numeric Keypad window and set the y-axis scale. Alternatively, press the *Autoscale* button to scale the y-axis so that it will show all the readings. The indicator by the *Autoscale* button shows whether autoscaling is active.

The numeric and graphical outputs are updated as new readings are made. The time between readings depends on the settings for that channel and any other channels that are also enabled. This can vary between 2 seconds and 5 minutes. The measurement sample time for a PRT or thermistor is <2s and for a thermocouple it is <1s. The reading rate for three PRTs with one sample per reading will therefore be <6s.

**Start Save button:** Press the *Start Save* button to record all the measurements being made. You will then be offered the choice (buttons) of storing the data to the *Internal* “DiskOnChip” (solid state drive) memory or an *External* USB flash

drive. Data stored to the internal memory can subsequently be transferred to an external USB flash drive using the *Backup Data* button in the *Instrument* tab (see section 3.7.9). The internal memory used has a capacity of at least 32Mbytes; this will accommodate approximately 1,300,000 PRT readings or about 30 days of continuous logging at the fastest rate. Select the destination for the data to open an Alpha-Numeric Keyboard window and enter a filename. An automatically incrementing default name will appear in the entry box, press *OK* to accept this or use the backspace and alpha-numeric keys to enter your preferred filename. If you try to use a filename that has already been used, you will have to enter the password to proceed (see section 3.11 for details on password protection). The *Shift* key toggles the alpha keys between upper and lower case. The indicator by the *Start Save* button in the *Single* tab shows whether readings are being recorded to a file. The measurements are written to the file in comma delimited ASCII text form allowing easy importation into Microsoft Excel™ or other applications.

### 3.5 The Multi Tab

Select this tab to see all three channels in numeric form only. The numeric display shows the last reading together with the mean and standard deviation for the most recent readings (the number of readings in the statistics is set in the *Settings* tab) for each of the channels that are enabled.

Single	Multi	Settings	Instrument
<input checked="" type="radio"/>			
<input type="button" value="Start Save"/>	Channel 1	<input type="text" value="0.0000008"/>	Volts
		<input type="text" value="0.000000753"/>	Mean of last 100
		<input type="text" value="0.000000016"/>	S.D. <input type="button" value="Clear"/>
	Channel 2	<input type="text" value="99.9983"/>	Ohms
		<input type="text" value="99.998279"/>	Mean of last 100
		<input type="text" value="0.000022"/>	S.D. <input type="button" value="Clear"/>
	Channel 3	<input type="text"/>	Rt/Rs
		<input type="text"/>	Mean
		<input type="text"/>	S.D. <input type="button" value="Clear"/>

**Clear buttons:** Press the *Clear* button to clear (reset) the statistics for each channel

The displayed values are updated as new readings are taken. The time between readings depends on the settings for that channel and any other channels that are also enabled. This can vary between 2 seconds and 5 minutes. The measurement time for a PRT or thermistor is <2s and for a thermocouple it is <1s. The reading rate for three PRTs with one sample per reading will therefore be <6s.

**Start Save:** Press the *Start Save* button to record all the measurements being made. You will then be offered the choice (buttons) of storing the data to the *Internal* “DiskOnChip” (solid state drive) memory or an *External* USB Flash Drive. Data stored to the internal memory can subsequently be transferred to an external USB Flash Drive using the *Backup Data* button on the *Instrument* tab (see section 3.7.9). The internal memory used has a capacity to at least 32Mbytes; this will accommodate approximately 1,300,000 PRT readings or about 30 days of continuous logging at the fastest rate. Select the destination for the data to open an Alpha-Numeric Keyboard window and enter a filename. An automatically incrementing default name will appear in the entry box, press *OK* to accept this or use the backspace and alpha-numeric keys to enter your preferred filename. If you try to use a filename that has already been used, you will have to enter the password to proceed (see section 3.11 for details on password protection). The *Shift* key toggles the alpha keys between upper and lower case. The indicator by the *Start Save* button in the *Multi* tab shows whether readings are being recorded to a file. The measurements are written to the file in comma delimited ASCII text form allowing easy importation into Microsoft Excel™ or other applications.

### **3.6 The Settings Tab**

Select this tab to configure each channel for the required measurements.

Single	Multi	Settings	Instrument
Channel		Units	
↑ 1 ↓ ...	● Disable	↑ Ohms ↓	
Thermometer		Current / mA	
↑ Default PRT ↓ ...	1.0000 ...		
Conversion		Samples per Reading	
↑ None ↓	↑ 1 ↓ ...		
Range / Ohms		Readings in Rolling Statistics	
↑ 125 ↓	↑ 100 ↓ ...		
Reference Channel		Reference Resistor	
↑ Internal 100R ↓ ...	↑ 100 ↓ ...		

**Channel box:** Use the up/down buttons to select the channel you wish to configure. Alternatively press the ellipses button to open a numeric entry window and select the channel directly. The ellipses button is particularly useful when the microK is used with microsKanner multiplexers, which can provide up to 90 expansion channels.

**Enable/Disable button:** Use this button to enable or disable a channel. Disable unused channels to skip measurements on that channel and reduce the cycle time through the channels. The nearby indicator shows whether the currently selected channel is enabled.

**Thermometer box:** Use the up/down buttons to select the required thermometer. Initially this box will contain only default PRT, Thermocouple or Thermistor. You can use these entries for uncalibrated thermometer sensors. If you add thermometers to the microK's Thermometer Database (see section 3.7.1), these will also appear in the list within this box. The ellipses button opens a list of all available thermometers and is useful if you have a large number of entries in the database.

**Conversion box:** If the selected thermometer is one of the default types, you can use the up-down buttons to select a standard polynomial function for converting the thermometer's base measurement to temperature. If the selected thermometer

is one that you have created in the Thermometer Database this box will be fixed and will be the conversion type defined for that thermometer.

**Range box:** Use the up/down buttons to select the required range. The microK has three ranges for each thermometer type. Use the 0.125V range for all thermocouples as this provides the most suitable input voltage range. The resistance ranges offered depend on the sense current (use the ellipses button by the *Current* box in this tab to change the current). Choose a resistance range that is greater than or equal to both the highest thermometer resistance and reference resistor value you intend to use.

**Reference Channel box (PRTs and thermistors only):** Use the up/down buttons to select the reference resistor used in the resistance measurement; either one of the internal reference resistors or the channel to which an external resistance standard is connected. Alternatively press the ellipses button to open the Reference Channel window and select the channel directly. The *External* button in this window allows you to select one of the microK's three external channels or any expansion channel provided by a microKanner.

**Reference Resistor box (PRTs and thermistors only):** If an internal reference resistor was selected in the *Reference Channel* box, this box will show the calibrated value of that resistor. If one of the input channels was selected in the *Reference Channel* box, this box will contain a list of the reference resistors in the microK's database (entered using the *Edit Resistors* button in the *Instrument* tab – see section 3.7.2) and “Uncalibrated”. Select the required resistor using the up/down buttons. Select “Uncalibrated” if you only want to make a resistance ratio measurement between two channels. The ellipses button opens a list of all available reference resistors and is useful if you have a large number of entries in the database.

**Reference Junction box (thermocouples only):** This contains 0°C, 0.01°C and a list of any input channels that have been configured to measure temperature. Choose 0°C or 0.01°C if you are using an external reference junction in an ice-point bath or water triple point respectively. Choose one of the measurement channels if you want to measure the temperature of the reference junction with a

thermometer sensor on that channel. The software will not allow you to use a thermocouple channel as the reference junction sensor (to avoid circular dependencies). You must specify a thermometer sensor for the reference junction channel that includes temperature conversion otherwise it will not appear in the *Reference Junction* box.

**Units box:** Use the up/down buttons to select the required units. The base units (resistance ratio “Rt/Rs” for PRTs or thermistors and “Volts” for thermocouples) are always available. “Ohms” will also be available (for PRTs and thermistors) if the value of the reference resistor is available (*Reference Resistor* not set to “Uncalibrated”). If the thermometer sensor chosen has a temperature conversion specified, then temperature units °C, °F and K are also available.

**Current box (PRTs and thermistors only):** Press the ellipses button to change the sense current. Use the buttons in the window that then opens to select the required sense current:

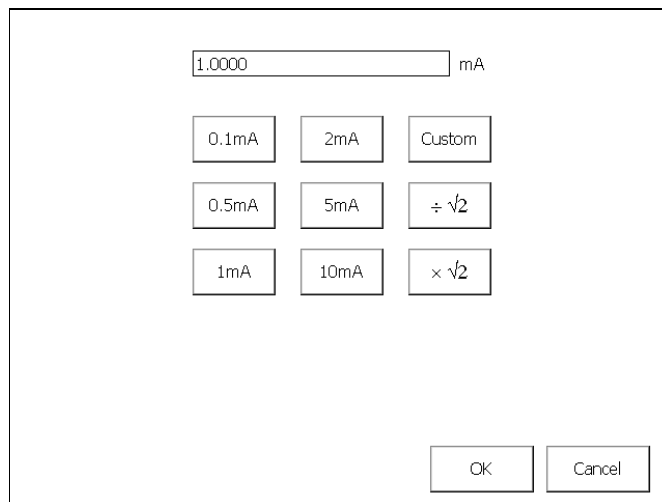

The standard PRT sense currents are available directly through the buttons provided. Press the *Custom* button to specify a different value (range 0 to 10mA), this will then open a Numeric Keypad window.

Buttons for  $\div\sqrt{2}$  and  $\times\sqrt{2}$  are included to make extrapolation to zero power easier since changing the current in a resistor by a factor of  $\sqrt{2}$  changes the power dissipated by a factor of 2. A PRT’s calibration may be defined at a specified current. Alternatively, it may be specified at zero power. In this case, you need to

determine what the resistance of the PRT would be at zero power. This is most easily done by measuring its resistance at the normal sense current and then increasing the current by a factor of  $\sqrt{2}$  and repeating the measurement. If you subtract the change in resistance from the first resistance value (at nominal current) this gives you the resistance of the PRT at zero power. Alternatively, the second measurement can be made at a current that has been reduced by a factor of  $\sqrt{2}$ . In this case the change in resistance should be subtracted from the second resistance value (current scaled by  $\sqrt{2}$ ) to determine the zero power resistance. The accuracy of the current source is 0.4%, so the uncertainty associated with this extrapolation back to zero power is only 0.8% of the measured resistance change, which should be very small. Other factors such as the fact that the PRT is not a constant resistance and so the power dissipated has changed between the two measurements are insignificant.

**Samples per Reading box:** Use the up/down buttons to select the number of samples you want to average together to form a single reading. Alternatively, press the ellipses button to open a Numeric Keypad window and enter the required number directly. The number of samples may be between 1 and 100 inclusive.

Increasing the number of samples will slow down the rate at which readings are made, but will also reduce the uncertainty associated with these readings (as shown by the standard deviations reported in the “Single” and “Multi” tabs). This uncertainty reduction is proportional to the square-root of the number of samples (for example: selecting 9 samples per reading will reduce the uncertainty associated with each reading by a factor of 3).

**Readings in Rolling Statistics box:** Use the up-down buttons to select the number of samples in the rolling statistics. Alternatively press the ellipses button to open a Numeric Keypad window and enter the value directly. Values between 1 and 1000 (inclusive) may be used.

### 3.7 The Instrument Tab

Select this tab to enter information into the microK's database (for thermometers and reference resistors), adjust instrument settings (GPIB address, time, date and passwords), backup/load instrument configurations or update the software:

Single	Multi	Settings	Instrument
<input type="button" value="Edit Thermometers"/>	System Calibration <input checked="" type="radio"/> OK	<input type="button" value="Port Settings"/>	
<input type="button" value="Edit Resistors"/>		<input type="button" value="Set Date and Time"/>	
<input type="button" value="Calibration"/>		<input type="button" value="Backup Data"/>	
<input type="button" value="Restart Software"/>		<input type="button" value="Clear Data Files"/>	
<input type="button" value="Update Software"/>		<input type="button" value="Backup Configuration"/>	
<input type="button" value="Change Password"/>		<input type="button" value="Load Configuration"/>	

#### 3.7.1 Edit Thermometers

Press [Edit Thermometers](#) to create, edit or delete a thermometer in the database.

You will be prompted to enter the password in order to proceed.

<input type="button" value="↑"/>	<input type="text" value="SPRT1"/>	<input type="button" value="↓"/>	Thermometer
Thermometer Name		Thermometer Type	
<input type="text" value="SPRT1"/>	<input type="button" value="..."/>	<input type="button" value="↑"/>	<input type="text" value="PRT"/>
Manufacturer's Name		Min Temperature / °C	
<input type="text" value="Isothermal Technology"/>	<input type="button" value="..."/>	<input type="text" value="0.00"/>	<input type="button" value="..."/>
Serial Number		Max Temperature / °C	
<input type="text" value="66032_123"/>	<input type="button" value="..."/>	<input type="text" value="660.00"/>	<input type="button" value="..."/>
Calibration Due		Conversion	
<input type="text" value="15/12/2010"/>	<input type="button" value="..."/>	<input type="button" value="↑"/>	<input type="text" value="ITS90"/>
<input type="button" value="New"/>	<input type="button" value="Delete"/>	<input type="button" value="Coefficients"/>	<input type="button" value="OK"/>

**Thermometer box:** Use the up/down buttons to select the thermometer you wish to edit or delete. Alternatively press the [New](#) key to create a new thermometer

entry. The default thermometer types are included in the list but cannot be edited or deleted.

**Thermometer Name box:** This box contains the name of the selected thermometer. If you are creating a new thermometer entry, the ellipses button by the box becomes active. Press this button to open an Alpha-Numeric Keyboard window and enter a name. The *Shift* key toggles the alpha keys between upper and lower case.

**Manufacturer's Name box:** This box contains the manufacturer of the selected thermometer. If you are creating a new thermometer entry, the ellipses button by the box becomes active. Press this button to open an Alpha-Numeric Keyboard window and enter a name. The *Shift* key toggles the alpha keys between upper and lower case.

**Serial Number box:** This box contains the serial number of the selected thermometer. If you are creating a new thermometer entry, the ellipses button by the box becomes active. Press this button to open an Alpha-Numeric Keyboard window and enter a serial number. The *Shift* key toggles the alpha keys between upper and lower case.

**Calibration Due box:** This box contains the date when calibration is due for the selected thermometer. If you are creating a new thermometer entry, the ellipses button by the box becomes active. Press this button to open a Date Entry window and enter a date. The ellipses buttons by the *Day*, *Month* and *Year* boxes in the Date Entry window open a Numeric Keypad window. Dates are checked for validity (including leap years) for dates up to 31<sup>st</sup> December 2099.

**Thermometer Type box:** This box contains the type of thermometer (PRT, Thermocouple or Thermistor). If you are creating a new thermometer entry, use the up/down buttons to select the thermometer type.

**Min Temperature box:** This box contains the minimum operating temperature for the selected thermometer. If you are creating a new thermometer entry, the ellipses button by the box becomes active. Press this button to open a Numeric

Keypad window and enter the minimum operating temperature for the thermometer.

**Max Temperature box:** This box contains the maximum operating temperature for the selected thermometer. If you are creating a new thermometer entry, the ellipses button by the box becomes active. Press this button to open a Numeric Keypad window and enter the maximum operating temperature for the thermometer.

**Conversion box:** This box contains the conversion to temperature units used for the selected thermometer. If you are creating a new thermometer entry, use the up/down buttons to select the required conversion.

**Coefficients button:** This button opens a window that allows you to enter the coefficients required for the temperature conversion. In the case of ITS-90, or thermocouples, these are the coefficients for the deviation function (the base conversion coefficients are fixed):

The screenshot shows a dialog box titled "Coefficients" for the ITS-90 conversion. It contains the following fields and controls:

- Conversion Name:** A text box containing "ITS90" and an ellipsis button.
- Conversion Type:** A dropdown menu showing "ITS-90".
- R(0.01):** A text box containing "25.5" and an ellipsis button.
- Coefficients for T < 0.01°C:**
  - a:** A text box containing "0" and an ellipsis button.
  - b:** A text box containing "0" and an ellipsis button.
- Coefficients for T > 0.01°C:**
  - a:** A text box containing "0" and an ellipsis button.
  - b:** A text box containing "0" and an ellipsis button.
  - c:** A text box containing "0" and an ellipsis button.
  - d:** A text box containing "0" and an ellipsis button.
  - W660.323:** A text box containing "0" and an ellipsis button.
- OK:** A button at the bottom left.

**New button:** Press this button to make a new thermometer entry into the microK's database (ellipses and up/down buttons by the boxes then become active).

**Delete button:** Press this button to delete the selected thermometer (or the current entry for a new thermometer) from the database.

**OK button:** Press this button to confirm the changes and close the Window.

### 3.7.2 Edit Resistors

Press the *Edit Resistors* button to create, edit or delete a reference resistor in the database. You will be prompted to enter the password in order to proceed.

The screenshot shows a dialog box titled "Resistor" with a search field at the top containing "WILKINS 25". Below the search field are five input fields, each with an ellipsis button to its right:

- Resistor Name: WILKINS 25
- Value: 24.98765
- Manufacturer's Name: Tinsley
- Serial Number: W151256
- Calibration Due: 30/10/2010

At the bottom of the dialog are three buttons: "New", "Delete", and "OK".

**Resistor box:** Use the up/down buttons to select the reference resistor you wish to edit or delete. Alternatively press the *New* key to create a new reference resistor entry. The internal reference resistors are included in the list but cannot be edited or deleted.

**Resistor Name box:** This box contains the name of the selected reference resistor. If you are creating a new reference resistor entry, the ellipses button by the box becomes active. Press this button to open an Alpha-Numeric Keyboard window and enter a name. The *Shift* key toggles the alpha keys between upper and lower case.

**Manufacturer's Name box:** This box contains the manufacturer of the selected reference resistor. If you are creating a new reference resistor entry, the ellipses button by the box becomes active. Press this button to open an Alpha-Numeric Keyboard window and enter a name. The *Shift* key toggles the alpha keys between upper and lower case.

**Serial Number box:** This box contains the serial number of the selected reference resistor. If you are creating a new reference resistor entry, the ellipses button by the box becomes active. Press this button to open an Alpha-Numeric

Keyboard window and enter a serial number. The *Shift* key toggles the alpha keys between upper and lower case.

**Calibration Due box:** This box contains the date when calibration is due for the selected reference resistor. If you are creating a new reference resistor entry, the ellipses button by the box becomes active. Press this button to open a Date Entry window and enter a date. The ellipses buttons by the *Day*, *Month* and *Year* boxes in the Date Entry window open a Numeric Keypad window. Dates are checked for validity (including leap years) for dates up to 31<sup>st</sup> December 2099.

**Value box:** This box contains the calibrated value for the selected reference resistor. If you are creating a new reference resistor entry, press the ellipses button to open a Numeric Keypad window and enter the calibrated resistance value (in ohms).

**New button:** Press this button to make a new thermometer entry into the microK's database (ellipses and up/down buttons by the boxes then become active).

**Delete button:** Press this button to delete the selected reference resistor (or the current entry for a new reference resistor) from the database.

**OK button:** Press this button to confirm the changes and close the Window.

### 3.7.3 Calibration

Press the *Calibration* button to open a Date Entry window and set a recalibration date for your microK. The microK will warn you if you attempt to use it past this recalibration date (you can disregard the warning and continue to use it, but the warning will continue to re-appear every hour until the out-of-calibration issue is resolved).

### 3.7.4 Restart Software

Press the *Restart Software* button to restart the microK software. This is useful if you have added or removed microsKanners and want to re-invoke the automatic discovery process without cycling the power.

### 3.7.5 Update Software

Press the *Update Software* button to update the software or firmware in your microK. The software runs on a 32-bit processor and provides the operator interface. The firmware runs on an 8-bit processor and controls the low-level hardware in the microK.

The new software (microk.exe) or firmware (microK version x\_xx.hex) should be located in the root directory of a USB flash drive connected to the front panel USB connector (some USB flash drives can take a long time to enumerate in Windows CE™ and become visible to the software. You should therefore wait 15 seconds between plugging in the drive and pressing the button). You will be warned that this operation will restart the software, press *Yes* if you wish to continue. If the software finds a more recent software or firmware on the flash drive you will be advised of the version levels and offered the opportunity to update to the later version, you will also be prompted to enter the password before proceeding. If the flash drive does not contain a more recent version, the software will simply restart.

If you are updating the firmware, you will need to cycle the power to the microK (instruction provided on-screen) before the update process starts (it will take about 5 minutes). The update software will only update either the software or firmware at each attempt, so if you are updating both you will need to press *Update Software* twice.

The software automatically checks any USB flash drive connected to the front panel at start-up. If a more recent software version is found, you will be offered the opportunity to upgrade. Some flash drives enumerate too slowly and so are not detected during the start-up routine; in this case you should use the manual update procedure described above.

### 3.7.6 Change Password

Press the *Change Password* button to change the security password. (see section 3.11 for details of password protected settings). A window will then open to allow you to change the password.

Old Password  ...

New Password  ...

Confirm New Password  ...

OK Cancel

You will need to enter the old password and the new one (twice to ensure that it has been correctly entered). Press the ellipses buttons by each of the password boxes to open an Alpha-Numeric Keyboard window and enter the relevant password. Your microK is shipped with the password set to “1234”. This should be changed, for security reasons, before using your instrument in earnest.

### 3.7.7 Port Settings

Press [Port Settings](#) to view and change the microK’s GPIB address:

RS232 Baud Rate

GPIB Address  ↑ ↓ ...

OK Cancel

Press the ellipses button to open a numeric entry window and change the GPIB address (valid range 1 to 30 inclusive). The Baud Rate box reports the baud rate for the RS232 port, but this cannot be changed.

### 3.7.8 Set Date and Time

Press *Set Date and Time* to change the date and/or time. This opens a window to allow you to enter the current date and time and to select the date format (dd/mm/yyyy or mm/dd/yyyy):

The screenshot shows a dialog box for setting the date and time. On the left, there are six rows of input fields: Year (2010), Month (8), Day (10), Hour (13), Minute (51), and Second (12). Each input field is followed by an ellipsis button (...). To the right of these fields is the 'Date Format' section, which contains two radio buttons: 'dd/mm/yyyy' (which is selected) and 'mm/dd/yyyy'. At the bottom right of the dialog box are two buttons: 'OK' and 'Cancel'.

Press the ellipses buttons by each box to open a Numeric keypad window and enter the required value.

Press *OK* to save the changes and close the window. Press *Cancel* to close the window without making any changes.

### 3.7.9 Backup Data

Press *Backup Data* to transfer data that has been saved to the internal memory (see section 3.4 or 3.5) to an external USB Flash Drive. You need to plug a USB Flash Drive into the front of the microK in order to use this facility. With some Flash Drives, it can take up to 15 seconds for these to enumerate and therefore be recognised by the Windows CE operating system, you therefore need to wait for 15s after plugging in the USB Flash Drive before attempting to transfer the data (otherwise a “No external drive present” warning will appear).

If a file with the same name is already present on the USB flash drive, you will be asked whether you wish to over-write it. To proceed, you will need to enter the password.

Files are transferred to the USB flash drive in directory \\microKData\serialnumber\data, where “serialnumber” is the serial number of the microK used to make the measurements. This means that you can have duplicate filenames for measurements, provided they are made with different instruments.

### **3.7.10 Clear Data Files**

Press *Clear Data Files* to delete the data files from the internal memory, this frees up space for new files to be recorded. You will be prompted to enter the password before proceeding.

Unless you are sure that you do not need any of the files in the internal memory, you should transfer all files from the internal memory to a USB flash drive (see section 3.7.9) before using this feature.

### **3.7.11 Backup Configuration**

Press *Backup Configuration* to save the current configuration (settings) of the microK. You will be prompted to enter the password before proceeding. You will then be offered the choice (buttons) of storing the configuration to the *Internal* “DiskOnChip” (solid state drive) memory or an *External* USB flash drive. Press the required button to open an Alpha-Numeric Keyboard window and enter a name for the configuration.

Configurations stored to a USB flash drive are located in directory \\microKData\serialnumber\backups, where “serialnumber” is the serial number of the microK. This means that you can have duplicate configuration names (filenames) for measurements provided they apply to different instruments. If you want to transfer a configuration from one microK to another, you will need to move the configuration file manually on the USB flash drive between the sub-directories for the two microKs.

### **3.7.12 Load Configuration**

Press *Load Configuration* to load a configuration (settings) for the microK. You will be prompted to enter the password before proceeding. You will then be offered the choice (buttons) of loading the configuration from the *Internal*

“DiskOnChip” (solid state drive) memory or an *External* USB flash drive. Press the required button and then use the up/down buttons to select the required configuration. Press *OK* to load the configuration, or press *Cancel* to close the Window without loading the configuration.

### **3.8 Using the Thermometer Database**

The microK contains a database that allows you to enter, review and edit information about the thermometers you use. You can then select a thermometer from this database and all the parameters associated with it will be loaded and used by the measurement system. This means that you do not need to enter information such as the calibration coefficients each time you use the thermometer and therefore avoids the associated risk of data entry errors.

The database also allows you to enter calibration due dates to ensure that you do not unwittingly use devices beyond their recalibration date. The microK will warn you if you attempt to use a thermometer past its recalibration date (you can disregard the warning and continue to use the thermometer, but the warning will continue to re-appear every hour until the out-of-calibration issue is resolved).

Enter data on the thermometers you use as reference standards or measurement devices into the microK’s database (see section 3.7.1). You can then use one of these thermometers by selecting it in the *Thermometer* box in the *Settings* tab (see section 3.6).

The database allows you to enter information about the thermometer:

- ‡ Thermometer Name (the name you use to refer to the thermometer)
- ‡ Manufacturer’s name
- ‡ Serial Number
- ‡ Calibration Due date
- ‡ Thermometer Type
- ‡ Minimum Temperature (operating)
- ‡ Maximum Temperature (operating)
- ‡ Conversion (algorithm for converting base reading to temperature)

Information in the database is password protected to help you comply with the requirements of accreditation bodies.

### **3.9 Using the Reference Resistors Database**

The microK contains a database that allows you to enter, review and edit information about the reference resistors you use. You can then select a reference resistor from this database and all the parameters associated with it will be loaded and used by the measurement system. This means that you do not need to enter its value each time you use it and therefore avoids the associated risk of data entry errors.

The database also allows you to enter calibration due dates to ensure that you do not unwittingly use devices beyond their calibration interval. The microK will warn you if you attempt to use a reference resistor past its recalibration date (you can disregard the warning and continue to use it, but the warning will continue to re-appear every hour until the out-of-calibration issue is resolved).

Enter data on the reference resistors you use with your resistance thermometers into the microK's database (see section 3.7.2). You can then use one of these reference resistors using the *Reference Resistor* box in the *Settings* tab (see section 3.6).

The database allows you to enter information about the reference resistor:

- ⌘ Resistor Name (the name you use to refer to the resistor)
- ⌘ Manufacturer's name
- ⌘ Serial Number
- ⌘ Calibration Due date
- ⌘ Value (calibrated value in ohms)

Information in the database is password protected to help you comply with the requirements of accreditation bodies.

### **3.10 Saving Instrument Configurations**

You can save the current configuration (settings) for the microK using the *Backup Configuration* button in the *Instrument* tab (see section 3.7.11). This is useful if you use the microK in a number of different ways (for example at different times you may use it to perform fixed-point calibrations on single SPRTs and comparison calibrations of a thermocouple against two SPRTs). You

can then reload the required configuration (see section 3.7.12) rather than having to enter all the setting for that particular measurement configuration individually.

### **3.11 Password Protection of Key Settings**

All settings and parameters that affect measurements are password protected. This helps you to establish working procedures that meet the requirements of accreditation bodies and should alleviate some of the concerns that accreditation bodies have about the integrity of measurements.

You need to enter the password to perform the following tasks:

- ⌵ create/edit/delete a thermometer database entry
- ⌵ create/edit/delete a reference resistors database entry
- ⌵ backup internal data to a USB flash drive
- ⌵ overwrite a data file on the USB flash drive
- ⌵ delete internal data files
- ⌵ backup a configuration
- ⌵ load a configuration
- ⌵ change the password
- ⌵ upgrade the software

## 4 Connecting Thermometer Sensors

### 4.1 The “Cable-Pod” Connectors

The Eichmann “Cable-Pod”™ connectors used on the microK have gold-plated tellurium-copper contacts. These generate exceptionally low thermal EMFs when connected to the copper terminations used on standards grade thermocouples.

The connectors accept 4mm plugs, bare wires or spade terminations.

Additionally, they are spaced on 19mm ( $\frac{3}{4}$ ”) pitch so that they can be used with standard 4mm-to-BNC adaptors (not supplied) for connecting to BNC terminated SPRTs. The mechanism is designed so that the clamping surface does not rotate as it clamps the wire in order to avoid damaging it.



The “Cable-Pod”™ mechanism is made from a high strength polymer but nonetheless may be subject to mechanical damage if the connectors are over tightened. Please tighten the terminals to a light “finger-tight” level in order to ensure that they are not subject to undue wear or premature failure. This is all that is required electrically – do not try to use the connector to provide strain relief or tension a cable.

### 4.2 Connecting PRTs (4-wire)

The microK’s resistance measurement system is optimised for high accuracy, 4-wire resistance measurement. The PRT should be connected to the chosen input channel in accordance with the schematic shown on the microK’s front panel, as follows:

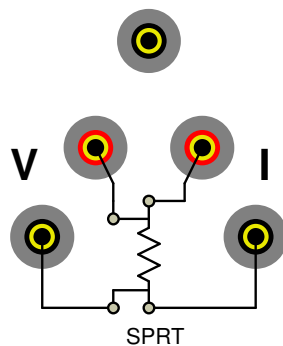

The top terminal should be connected to the screen of the SPRT's lead to minimise electrical noise picked up by the wires.

### 4.3 Connecting PRTs (3-wire)

The microK can be connected to 3-wire PRTs, although it will not automatically compensate for cable resistance. The two red terminals should be connected together and then connected to the 'single' end of the 3-wire PRT as follows:

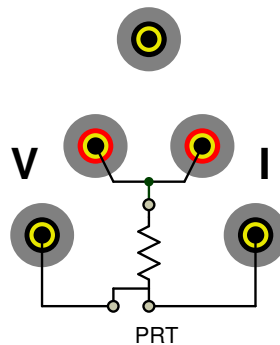

The connection to the 'single' end of the 3-wire PRT should be short (have a low resistance) in order to minimise the effect of lead resistance on the measurement.

The top terminal should be connected to the screen of the PRT's lead to minimise electrical noise picked up by the wires.

### 4.4 Connecting PRTs (2-wire)

The microK can be connected to 2-wire PRTs. The two red and two black measurement terminals should be connected together and then connected to the PRT as follows:

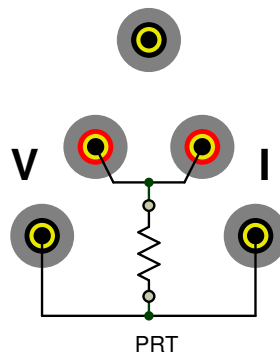

The connections to the PRT should be short (low resistance) in order to minimise the effect of lead resistance on the measurement. Alternatively, the connections can use remote sensing (using the 4-wire measurement capability of the microK) to eliminate the effect of lead resistance completely. In this arrangement, the current and voltage sense connections are kept separate and are only joined close to the PRT:

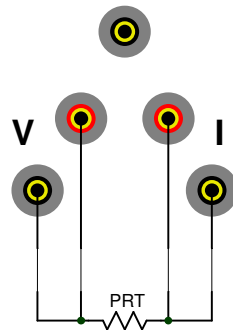

The top terminal should be connected to the screen of the PRT's lead to minimise electrical noise picked up by the wires.

#### **4.5 Connecting Thermocouples (external Ice Point or WTP)**

The microK's measurement system uses active guarding. As a result, the voltage measurement system is floating until it is connected to the sense current terminals. In order to measure the voltage on a thermocouple, the two current terminals should be connected to each other and to the red voltage sense terminal:

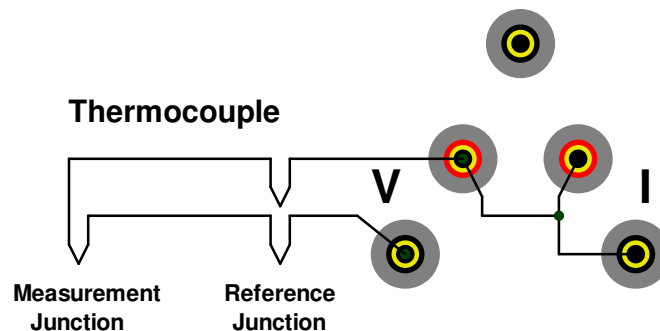

The most accurate thermocouple measurements are made with the reference junction immersed in an ice-point bath (or water-triple-point). The microK

supports this arrangement by allowing you to specify the temperature of the reference junction as 0°C or 0.01°C (see section 3.6).

#### **4.6 Connecting Thermocouples (using RJ compensation)**

It is possible to measure the temperature of the reference junction and compensate for the associated EMF at this junction. The reference junction can be measured using a PRT or thermistor connected to another measurement channel:

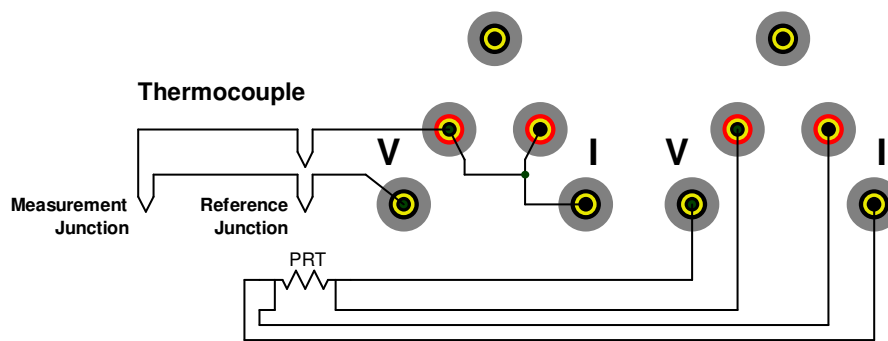

The microK supports this arrangement by allowing you to use a temperature measured by another input channel as the reference junction temperature. This technique is less accurate than using an ice-point (or water-triple-point) due to the additional uncertainties associated with the PRT used to monitor the reference junction and any temperature gradients that result in a difference between the temperature of the PRT and the reference junction.

#### **4.7 Connecting Thermistors**

The microK can be connected to thermistors using the same arrangement as for 2-wire PRTs (see section 4.4):

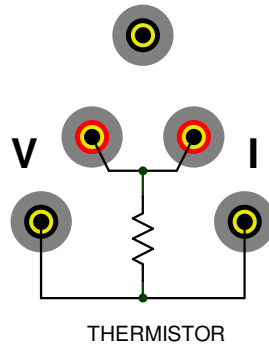

Because the resistance of thermistors used for temperature measurement is much higher than for PRTs, lead resistance is not normally a problem.

Use an external reference resistor with thermistors since the resistance of the internal standards is too low. Thermistors have much higher temperature coefficients than PRT, so the tolerances on the reference resistor are correspondingly less demanding, making them relatively inexpensive.

The top terminal should be connected to the screen of the thermistor's lead to minimise electrical noise picked up by the wires. The high resistance of thermistors makes them more prone to picking up electrical noise, it is therefore even more important to use a screened cable and connect this to the screen terminal on the microK than when using PRTs.

## **5 Good Practice Guidelines**

### ***5.1 Looking After Your microK***

Your microK is a precision electronic instrument intended for indoor use in a laboratory or office environment. Nonetheless, it has been designed to be as robust as practical and will provide many years of service, provided it is properly maintained.

We recommend that you return your microK to Isothermal Technology or one of our approved service centres on an annual basis for calibration. Isothermal Technology has developed a calibration kit for the microK. Contact Isothermal Technology or one of our appointed distributors if you wish to purchase a kit to calibrate the microK yourself. The microK should require little maintenance between calibrations other than routine cleaning.

Under no circumstances should you use sharp or unsuitable objects (such as ball-point pens) on the touch screen as this will lead to premature failure. It is also a good idea to ensure that you have clean hands when using the touch screen. You should ensure that you do not have contaminants such as adhesives or solvents on your fingers when touching the screen as these will be difficult to remove without damaging the screen.

The touch screen can be cleaned with a damp (not wet) cloth. Use either a proprietary screen cleaner (suitable for PC flat panel displays) or water and a little mild liquid soap on a lint-free cloth to wipe the touch screen. Dry the screen immediately after cleaning with a lint-free cloth. The rest of the microK should not require cleaning as often as the display, and can be cleaned in the same way as the screen. Never use abrasive cleaners (such as 'cream' cleaners) on your microK.

### ***5.2 Making a Good Electrical Measurement***

Although the microK is intended for use in temperature metrology, its base measurements are electrical (resistance or voltage). The limited sensitivity of

PRTs and thermocouples means that in order to achieve uncertainties at the mK level, we need to make electrical measurements that rival those of a good electrical metrology laboratory. For example, for a  $25\Omega$  SPRT a 1mK temperature uncertainty corresponds to  $100\mu\Omega$  resistance uncertainty. With a 1mA sense current, this corresponds to a voltage uncertainty of  $0.1\mu\text{V}$ .

The microK has been optimised for electromagnetic compatibility (minimising emissions and maximising immunity). However, since the microK is capable of measuring to such low signal levels it is worthwhile adopting good electrical measurement practices. Here are a few guidelines:

- ⚡ The most sensitive points are the inputs to the microK (measuring to better than  $0.1\mu\text{V}$ ). Whilst the microK will work satisfactorily with just a four wire connection to the PRT or reference resistor (using the voltage sense and current terminals marked “V” and “I” respectively), it is better to use a screened cable and to connect the screen to the measurement ground terminal above the input terminals:

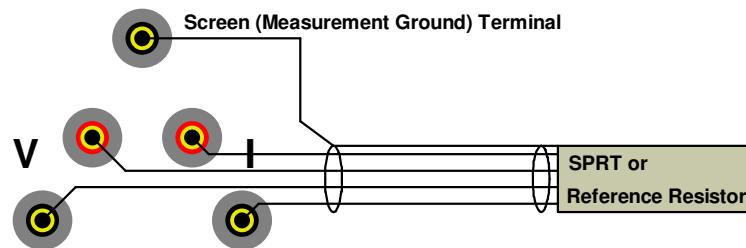

The screen should also be connected to the outer sheath of the SPRT (if it is metal clad) or the case of the reference resistor. The use of screened cables is more important when the microK is used with thermistors, which have a higher resistance than PRTs or thermocouples.

- ⚡ Keep the cables to the microK input terminals away from other cables that might be sources of electrical noise (for example electrical supplies to furnaces).
- ⚡ The insulation in high temperature furnaces (any that ‘glow’) begins to conduct at higher temperatures. This can cause high common-mode voltages on any thermometer in the furnace. Whilst the microK is designed to reject common-mode DC and AC signals (at both 50 and

60Hz), it is good practice to minimise them. It is common practice to use a metal equalising block in a furnace when performing comparison calibrations. This should be connected to the safety earth of the electrical supply (most furnaces designed for temperature metrology applications are fitted with a device to 'earth' the equalising block). Do not 'earth' the equalising block to the screen/measurement ground terminals on the front panel of your microK as this is not connected to the safety earth of the electrical supply.

- ⌘ Provide a 'clean' electrical environment in your temperature laboratory. It may be useful to filter your electrical supply into the laboratory especially if other heavy electrical machinery is being used nearby on the same supply (the microK has very good immunity to electrical noise conducted along the electrical supply, but other equipment in your laboratory may be more sensitive). It is worth avoiding using sources of electrical signals or noise in your laboratory. Examples include furnaces with triac controls (especially those that 'chop' the electrical supply part way through a cycle – better controllers switch only at the zero-crossing point to 'chop' whole cycles only), mobile phones (the microK is not significantly affected by mobile phones, but other equipment may be more sensitive).

## 6 The microK Technology

The microK uses a number of new technologies and measurement techniques to achieve performance that has not previously been available with potentiometric measurement systems.

### 6.1 The ADC

The ADC (Analogue-to-Digital Converter) in a precision instrument is the ‘measurement engine’. Its performance is the starting point for achieving low measurement uncertainty. The microK uses a completely new type of ADC, which was designed specifically for this product. It is based on the well established  $\Sigma$ - $\Delta$  (sigma-delta) technique but uses multi-bit feedback to achieve performance that is not achievable with conventional  $\Sigma$ - $\Delta$  ADCs.

In a conventional  $\Sigma$ - $\Delta$  ADC, the analog input signal is subtracted from the output of a 1-bit DAC before being filtered by a series of cascaded integrators. The signal then passes to a 1-bit ADC that drives the DAC and forms a feedback loop

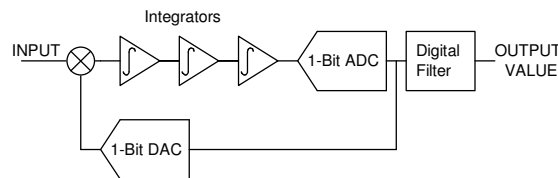

#### Conventional $\Sigma$ - $\Delta$ ADC

The extremely high, low-frequency loop-gain of the cascaded integrators ensures that the input signal is balanced against the output of the DAC so that the average value of the 1-bit data stream from the DAC equals the input signal. A low-pass digital filter is then used to extract the converted value from the 1-bit data stream.

Another way of viewing the operation of a  $\Sigma$ - $\Delta$  ADC is to consider what is happening in the frequency domain. The over-sampling used in  $\Sigma$ - $\Delta$  converters means that the quantisation noise caused by the 1-bit ADC is spread over a wide bandwidth, whereas the signal we are looking for is unaffected by this over-sampling. The digital filter selects the narrow bandwidth of the required signal. The amount of quantisation noise in this bandwidth is relatively small because the over-sampling spreads the noise power over such a large bandwidth.

The quantisation noise on the converted signal can be reduced by increasing the sampling rate, but it becomes increasingly difficult to maintain performance as the clock rate of the system increases. Another way to reduce the noise would be to use a multi-bit ADC and DAC in the feedback loop. This would not normally be feasible since the DAC would carry the full accuracy burden of the measurement system. However, by using a PWM (Pulse-Width Modulation) DAC, in which the output is a signal of fixed frequency and amplitude but variable pulse width, we turn the problem of producing accurate voltage or current levels into one of accurate timing. Whereas achieving sub-ppm voltage accuracy with a DAC would not be feasible in this sort of product, it is possible to achieve the corresponding timing accuracies.

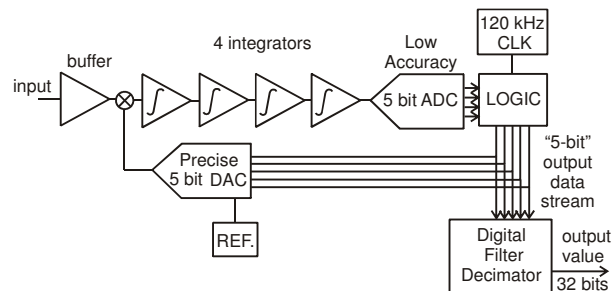

### Multi-Bit $\Sigma$ - $\Delta$ ADC

The timing demands of the PWM DAC are, however, far from trivial. The digital filter has to work at the  $\Sigma$ - $\Delta$  ADCs clock rate. In the microK, this digital part of the  $\Sigma$ - $\Delta$  ADC is implemented in a fast FPGA, which provides both the digital filter that decimates the DAC output (to extract the converted value) and controls the feedback DAC. The full-scale pulse-width on the PWM DAC is only 5 $\mu$ s, so

the 0.2ppm linearity achieved with the  $\Sigma$ - $\Delta$  ADC corresponds to a timing accuracy of 1ps, or about the time it takes for the electrical signals in the control system to travel 0.3mm.

It might appear that the reduction in quantisation noise from using multi-bit feedback in a  $\Sigma$ - $\Delta$  ADC would be directly proportional to the ADC/DAC resolution. However, the reduced differential gain inherent in the higher resolution DAC greatly improves loop stability too. This allows the use of more orders of integration and higher loop gain giving a disproportionate improvement in quantisation noise. With the 5-bit system used in the microK, the quantisation noise is reduced by a factor of 600 so that the performance of the microK is not limited by the  $\Sigma$ - $\Delta$  ADC technique but by the electronic devices used in the ADC and the rest of the measurement system.

Another benefit of the new ADC is its speed. The implementation used in the microK provides conversions to full accuracy in 100ms. This, together with the use of solid-state switching, allows for a very fast reversal rate, which in turn helps to eliminate the effect of any thermal EMFs and reduce the noise (since the system can operate above the corner frequency of the amplifiers 1/f noise).

## 6.2 Substitution Topology

In conventional potentiometric instruments, a common DC current is passed through a thermometer ( $R_X$ ) and reference resistor ( $R_S$ ). A voltmeter is switched between reading the voltage across  $R_X$  and  $R_S$  and the ratio of the two readings ( $n$ ) is calculated:

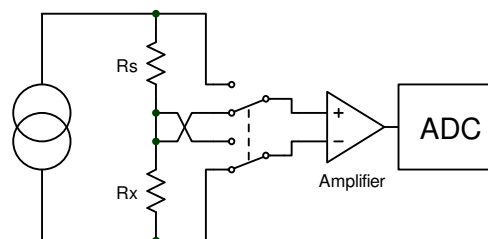

**Conventional Potentiometric Resistance Measurement**

A significant source of error with this measurement topology is the common-mode rejection ratio of the input amplifier. The common-mode signal at the input to the amplifier changes between the two measurements and will lead to an error at the input to the ADC.

In order to eliminate this source of error, the microK uses a substitution topology in which there is a single point of measurement in the system into which the SPRT and Reference Resistor are switched alternately.

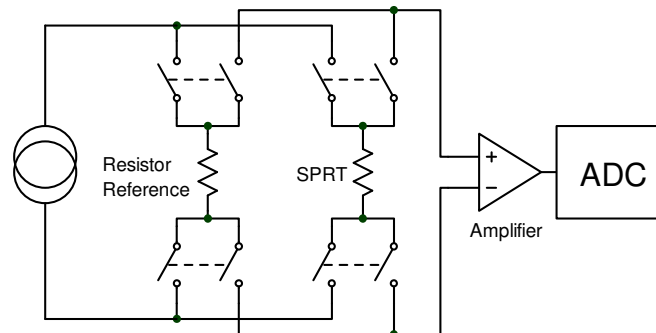

### Substitution Measurement Topology

This adds complexity and cost to the design, but ensures that there is no change to the common-mode signal between the measurement of the reference resistor and the thermometer. This approach would normally, however, increase the demands on the current source. In the conventional topology, the current is common to both the reference resistor and the thermometer. In the substitution topology, the voltage at the output of the current source changes between the measurement on the SPRT and the Reference Resistor and the current source must accommodate this change without any significant change to the sense current.

The current source in the microK has a very high output impedance, such that the sense current will not change significantly between the measurement of the reference resistor and the thermometer. In addition, the whole measurement system is actively guarded so that both the voltage at the output of the current source and the common-mode voltage across the device being measured do not change.

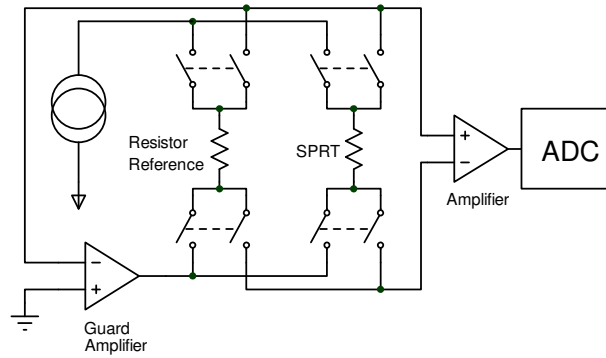

### Guarded Measurement System

The Guard Amplifier senses the potential at the ‘top’ of the measurement system and drives the opposite end in order to maintain it at ground potential. In this way, both the current source and Amplifier see no significant change in voltage/common-mode signal between the measurements of the Reference Resistor and the SPRT.

### 6.3 Minimising Thermal EMFs

Thermal EMFs (EMFs generated as the result of junctions between dissimilar metals at different temperatures) are a potential source of error when working at this precision. These can largely be eliminated when measuring resistance thermometers by reversing the current and averaging the measurements (the offsets in the two measurements cancel each other out when the readings are averaged together). However, this technique cannot be used when measuring temperature with thermocouples, so the thermal EMFs need to be eliminated at source. For this reason, we used tellurium-copper (gold plated) as the connector contact material, since this combines good mechanical properties with extremely low thermal EMFs against the copper terminations of a thermocouple.

In order to eliminate thermal EMFs from the measurement system (already small), the input connections are reversed immediately behind the input terminals. Measurements made with and without the reversal are then averaged together to eliminate the thermal EMFs. The limitation is then the thermal EMFs generated by the devices used to implement this reversal.

## **6.4 Solid-State Switching**

One of the most common sources of failure in instruments of this complexity is the contacts in switches, relays, connectors and potentiometers. For this reason, the microK was designed to have no switches (apart from the on/off switch), mechanical relays or potentiometers. The switches normally used for the operator interface have been replaced with a combination of an industrial grade touch-screen over a full-colour VGA LCD, making the instrument both reliable and easy to use. The internal connectors are limited to three ribbon cables (with gold plated contacts) for signal interconnections plus a small number of connectors for the AC power and internal DC supply.

Conventional instruments of this type use mechanical relays for some or all of the signal routing. The microK uses only solid-state switching. The thermal EMFs from the metal-silicon junctions in solid-state switching devices are potentially higher than for mechanical relays under the same temperature gradient. However, the very small size of the die within the semiconductor devices means that there would be little opportunity for thermal gradients, giving them a strong advantage over their mechanical counterparts. In practice the thermal EMFs from solid-state switching are significantly less than even the best mechanical relays. As a result, the microK achieves voltage offsets significantly less than 250nV.

## **6.5 Inherent Stability**

The current reversals used to eliminate thermal EMFs from resistance measurements together with true 4-wire resistance measurement have the effect of ensuring an intrinsically stable zero with time and temperature. The voltage at the amplifier input when measuring a short-circuit will be the same whichever current direction is used. The process of averaging the measurements therefore yields zero (with uncertainty determined by the system noise).

In a similar way, the substitution technique means that the measurement system is also inherently stable at unity ratio since the voltages measured for a reference resistor and thermometer of the same value will be identical. There is, after all, no difference between these two measurements apart from the fact that they are

taken at slight different times. The system noise will again determine the uncertainty of this unity ratio measurement.

## **6.6 Eliminating Self-Heating Effects**

Although the sense currents used with SPRTs are small, they can still generate self-heating ‘errors’ of several mK. The most accurate SPRTs typically have very lightly supported elements so the self-heating effect is ironically worst in those SPRTs designed for the most accurate measurements.

The microK includes individual “keep-warm” current sources for each of the three input channels. These replace the sense current when a channel is not being measured and ensure that the power dissipated in an SPRT remains constant.

The most accurate measurements with an SPRT involve measuring its resistance at two sense currents and then extrapolating back to the zero-power value. The microK’s user interface provides a simple feature to allow the sense current to be scaled by a factor of root-two (a factor of 2 in power) to make this technique easy for the user to implement (see section 3.6).

## 7 Calibration

The ADC and measurement topology used in the microK are inherently very stable with both time and temperature. The stability of the microK is primarily determined by its internal standards (a zener reference for voltage and bulk metal foil resistors for resistance). We have used the best available components for these internal standards; a Linear Technology precision zener reference of the type used for voltage transfer standards in electrical metrology and Vishay hermetically sealed bulk metal foil resistors. To keep your microK operating within its performance specification, it should be recalibrated annually. Please contact Isothermal technology to arrange this calibration.

### 7.1 Checking Calibration

The calibration can be checked by measuring known standards with the microK. The calibration should be performed in a temperature controlled environment between 19°C and 25°C. The microK should be powered up and left to stabilise in the calibration environment for at least 4 hours before checking or adjusting its calibration.

#### 7.1.1 Checking the Master Current Source

The microK current source has 3 ranges (0-0.1mA, 0-1mA and 0-10mA). Check these by connecting a calibrated ammeter (or DMM) across the current terminals of channel 1 and connecting both the sense inputs to the red current terminal:

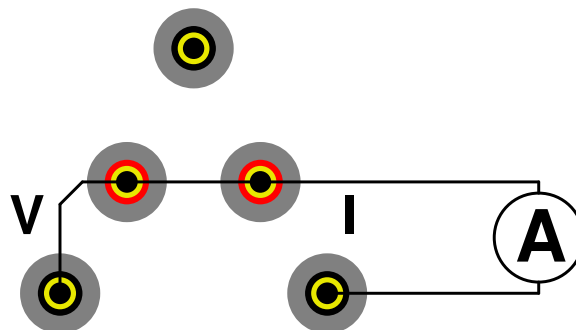

Checking the master current source involves connecting a PC to your microK (using a null-modem RS232 cable) and sending commands to it from Hyperterminal (part of the standard Windows operating system installation) or

another terminal emulator. For further details of how to connect a PC to your microK see section 8.

Once you have established communication with your microK, type in the following commands and check that the measured current is within the given limits:

<b>command</b>	<b>current limits</b>
TEST:CURREN 0.1	0.0996 to 0.1004 mA
TEST:CURREN 1	0.996 to 1.004 mA
TEST:CURREN 10	9.96 to 10.04 mA
TEST:CURREN -0.1	-0.09966 to -0.1004 mA
TEST:CURREN -1	-0.9966 to -1.004 mA
TEST:CURREN -10	-9.96 to -10.04 mA

## **7.1.2 Resistance Measurements**

The current reversal used by the microK to eliminate the effect of thermal EMFs means that it has an inherently stable zero for resistance measurement. The zero ohms test does not form part of the calibrations process but is used to confirm correct operation of the measurement system. It only needs to be checked on one channel.

### **7.1.2.1 Zero Ohms Check**

Start by applying a four terminal short-circuit to channel 1. This involves shorting out the voltage sense terminals (marked “V”) and the current terminals (market “I”) and then making a single connection between these two set of terminals. The objective is to ensure that none of the sense current passes along the wire between the voltage sense terminals. This can easily be achieved using a single piece of un-insulated wire:

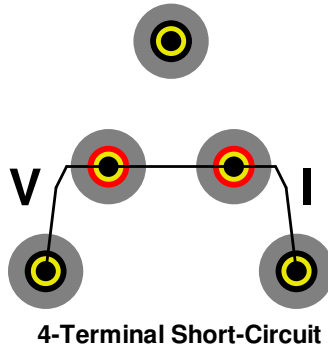

Configure the microK to measure a Default PRT at 1mA against the internal 100Ω reference on the 125Ω range on channel 1 (other channels disabled). Set the units to Ohms and use 1 sample per reading and 100 readings in the rolling statistics (see section 3.6). Select the *Single* tab and clear the statistic. After the microK has collected at least 100 readings (shown as *Mean of last...* in the *Single* tab, check that the *Mean* is less than 0.00001 (10μΩ i.e. 0.08ppm of the 125Ω range) and that the standard deviation (*S.D.*) is less than 0.00005.

#### 7.1.2.2 400 Ω Internal Reference Resistor

Connect a stable external resistance standard with a nominal value of 100Ω to channel 1. Ideally, this should be a Wilkins resistor with a recent (traceable) calibration certificate maintained at a constant temperature in an oil bath.

Configure the microK to measure a Default PRT at 1mA against the internal 400Ω reference on the 500Ω range on channel 1 (other channels disabled). Set the units to Ohms and use 1 sample per reading and 100 readings in the rolling statistics (see section 3.6). Select the *Single* tab and clear the statistics. After the microK has collected at least 100 readings (shown as *Mean of last...* in the *Single* tab, check that the *Mean* agrees with the calibrated value of the resistance standard to within 2.5ppm (half of the specification limit) of the calibrated value and that the standard deviation (*S.D.*) is less than 0.00008.

### 7.1.2.3 100 $\Omega$ Internal Reference Resistor

Repeat the procedure for checking the 400 $\Omega$  internal reference (see section 7.1.2.2), but configure the microK to measure a Default PRT at 1mA against the internal 100 $\Omega$  reference on the 125 $\Omega$  range on channel 1.

### 7.1.2.4 25 $\Omega$ Internal Reference Resistor

Repeat the procedure for checking the 400 $\Omega$  internal reference (see section 7.1.2.2), but configure the microK to measure a Default PRT at 1mA against the internal 25 $\Omega$  reference on the 125 $\Omega$  range on channel 1.

### 7.1.2.5 10 $\Omega$ Internal Reference Resistor

Connect a stable external resistance standard with a nominal value of 10 $\Omega$  to channel 1. Ideally, this should be a Wilkins resistor with a recent (traceable) calibration certificate maintained at a constant temperature in an oil bath. Repeat the procedure for checking the 400 $\Omega$  internal reference (see section 7.1.2.2), but configure the microK to measure a Default PRT at 5mA against the internal 10 $\Omega$  reference on the 25 $\Omega$  range on channel 1.

### 7.1.2.6 1 $\Omega$ Internal Reference Resistor

Connect a stable external resistance standard with a nominal value of 1 $\Omega$  to channel 1. Ideally, this should be a Wilkins resistor with a recent (traceable) calibration certificate. Configure the microK to measure a Default PRT at 10mA against the internal 1 $\Omega$  reference on the 13 $\Omega$  range on channel 1 (other channels disabled). Use 1 sample per reading and 100 readings in the rolling statistics (see section 3.6). Select the *Single* tab and clear the statistic. After the microK has collected at least 100 readings (shown as *Mean of last...* in the *Single* tab, check that the *Mean* agrees with the calibrated value of the resistance standard to within 2.5ppm (half of the specification limit) of the calibrated value and that the standard deviation (*S.D.*) is less than 0.000005.

### 7.1.3 Voltage Measurements

The automatic input reversal of used by the microK when measuring voltage provides good zero stability. However, small differences between the thermal EMFs generated by the devices used to make these reversals on each channel mean that the zero offset needs to be checked for each channel. Once the zeros offsets have been checked/adjusted, it is only necessary to check the span on one channel since this part of the measurement system is common to all the channels.

#### 7.1.3.1 Zero Voltage Offsets

Short out the 4 measurement terminals on all 3 channels using a piece of un-insulated copper wire (use pure copper wire to avoid generating unwanted thermal EMFs) for each channel:

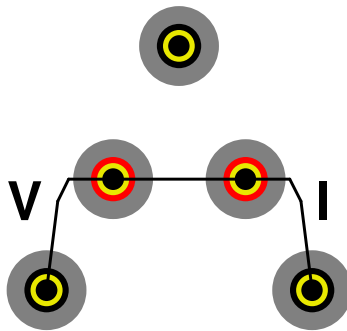

Configure the microK to measure a Default Thermocouple on the 0.125V range with units of Volts. Use 1 sample per reading and 100 readings in the rolling statistics (see section 3.6). Select the *Multi* tab and clear the statistics for all 3 channels. After the microK has collected at least 100 readings (shown as *Mean of last...* in the *Multi* tab, check that the *Mean* for each channels is less than 0.000000250 (0.25 $\mu$ V) and that the standard deviation (*S.D.*) is less than 0.000000050 (0.05 $\mu$ V).

#### 7.1.3.2 Voltage Span Check

Connect a stable, low noise voltage source with a nominal value of 50mV to channel 1 of the microK using low thermal EMF wire and connectors (copper or

an alloy such as tellurium–copper that has a high copper content and low thermal EMF to pure copper. Brass connectors must NOT be used):

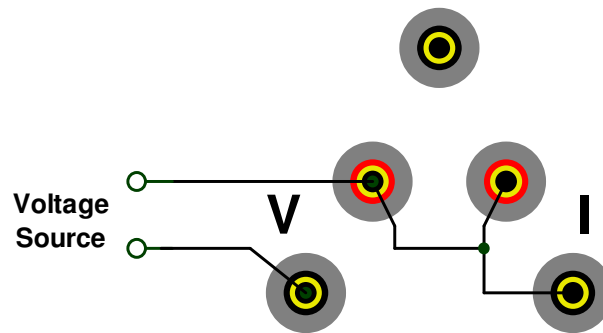

Configure the microK to measure a Default Thermocouple on the 0.125V range with units of Volts. Use 1 sample per reading and 100 readings in the rolling statistics (see section 3.6). Select the *Single* tab and clear the statistics. After the microK has collected at least 100 readings (shown as *Mean of last...* in the *Single* tab, check that the *Mean* value agrees with the applied voltage to within 0.000000250V (0.25 $\mu$ V) and that the standard deviation (*S.D.*) is less than 0.000000050V (0.05 $\mu$ V).

Repeat the procedure with the voltage source set to -50mV.

## 7.2 Adjusting Calibration

This section describes the procedures for adjusting the internal reference standards and the input offset voltages. These can be performed by the user or a third party calibration provider, subject to the availability of the standards specified below. Isothermal Technology additionally checks the temperature coefficient of the zener reference and the linearity of the microK against an RBC (resistance bridge calibration) with an uncertainty of 0.01ppm. We therefore recommend that you return your microK to Isothermal Technology or one of its appointed service centres annually for a comprehensive instrument calibration.

There are no potentiometers inside the microK to adjust, calibration is implemented in software so can be performed without removing the cover from your microK. Calibration is adjusted via the RS232 interface on the rear of the microK. Connect the microK to a PC (using a 9-pin null-modem RS232 cable)

and establish an RS232 connection with it using Hyperterminal at 9,600 Baud (for further details of how to connect a PC to your microK see section 8.1). Confirm that the RS232 link is working by typing in `*IDN?` (terminate this and all commands shown in this section by pressing the carriage return or enter key). The microK will respond with a string in the form:

Isothermal Technology, microK 400,10-P190,firmware version 3.17

The calibration of your microK is password protected. Unlocked the calibration to allow calibration adjustment using the command `CAL:UNL password`, where *password* is the calibration system password (NOT necessarily the same as the password used in the touch screen operator interface. The password is initially set to “1234” but should be changed for security reasons (see section 10.4.33). You can now use the SCPI commands (see section 10.4) detailed below to adjust the microK’s calibration.

### 7.2.1 Calibrate Master Current Source

The microK’s current source has 3 ranges (0-0.1mA, 0-1mA and 0-10mA). The tolerance between the ranges is sufficiently small that it is only necessary to calibrate the 1mA range in order to achieve the full performance specification.

Connect a calibrated ammeter (or DMM) across the current terminals of channel 1 and connect both the sense inputs to the red current terminal:

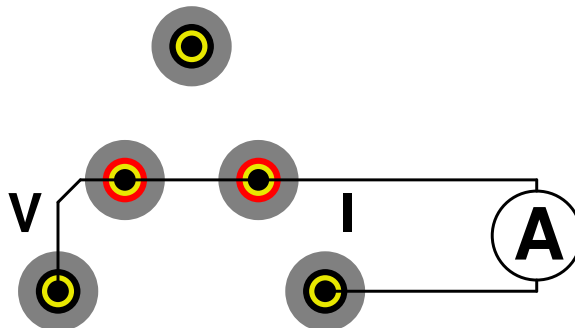

Send the command `TEST:CURR 1` to your microK from Hyperterminal (this forces the microK to source 1mA on channel 1). Measure the current and then

type in the command **CAL:CURR *current*** , where *current* is the measured value. Now type in **TEST:CURR 1** again to update the current source. The ammeter should now read 1mA ± 0.0003mA.

Check the other current ranges by typing in the following commands and checking that the current is within the given limits:

<b>command</b>	<b>current limits</b>
TEST:CURR 0.1	0.09975 to 0.10025 mA
TEST:CURR 10	9.975 to 10.025 mA
TEST:CURR -0.1	-0.09975 to -0.10025 mA
TEST:CURR -1	-0.9975 to -1.0025 mA
TEST:CURR -10	-9.975 to -10.025 mA

## 7.2.2 Calibrating the 400 Ω Internal Reference Resistor

Connect a stable external resistance standard with a nominal value of 100Ω to channel 1. Ideally, this should be a Wilkins resistor with a recent (traceable) calibration certificate maintained at a constant temperature in an oil bath.

Configure the microK to measure a Default PRT at 1mA against the internal 400Ω reference on the 500Ω range with channel 1 (other channels disabled). Set the units to ratio (Rt/Rs) with 1 sample per reading and 100 readings in the rolling statistics (see section 3.6). Select the *Single* tab and clear the statistics. After the microK has collected at least 100 readings (shown as *Mean of last...* in the *Single* tab, record the *Mean* value and check that the standard deviation (*S.D.*) is less than 0.000000100. Calculate the value of the internal resistor from:

$$R_{400} = \frac{\text{external reference}}{\text{ratio}}$$

Adjust the value assigned to the internal 400Ω reference resistors by typing in the command:

**CAL:REF205 *R400***

The value entered can be read back using **CAL:REF205?**. Check the new value assigned to the internal 400Ω reference resistor (see section 7.1.2.2).

### 7.2.3 Calibrating the 100 $\Omega$ Internal Reference Resistor

Repeat the procedure for calibrating the 400 $\Omega$  internal reference (see section 7.2.2), but configure the microK to measure a Default PRT at 1mA against the internal 100 $\Omega$  reference on the 125 $\Omega$  range with channel 1. The command to adjust the value assigned to the 100 $\Omega$  internal reference is:

`CAL:REF204 R100`

Where *R100* is the value calculated for the 100 $\Omega$  internal reference.

### 7.2.4 Calibrating the 25 $\Omega$ Internal Reference Resistor

Repeat the procedure for calibrating the 400 $\Omega$  internal reference (see section 7.2.2), but configure the microK to measure a Default PRT at 1mA against the internal 25 $\Omega$  reference on the 125 $\Omega$  range with channel 1. The command to adjust the value assigned to the 25 $\Omega$  internal reference is:

`CAL:REF203 R25`

Where *R25* is the value calculated for the 25 $\Omega$  internal reference.

### 7.2.5 Calibrating the 10 $\Omega$ Internal Reference Resistor

Connect a stable external resistance standard with a nominal value of 10 $\Omega$  to channel 1. Ideally, this should be a Wilkins resistor with a recent (traceable) calibration certificate maintained at a constant temperature in an oil bath. Repeat the procedure for calibrating the 400 $\Omega$  internal reference (see section 7.2.2), but configure the microK to measure a Default PRT at 5mA against the internal 10 $\Omega$  reference on the 25 $\Omega$  range with channel 1. The command to adjust the value assigned to the 10 $\Omega$  internal reference is:

`CAL:REF202 R10`

Where *R10* is the value calculated for the 10 $\Omega$  internal reference.

### 7.2.6 Calibrating the 1 $\Omega$ Internal Reference Resistor

Connect a stable external resistance standard with a nominal value of 1 $\Omega$  to channel 1. Ideally, this should be a Wilkins resistor with a recent (traceable)

calibration certificate. Repeat the procedure for calibrating the 400 $\Omega$  internal reference (see section 7.2.2), but configure the microK to measure a Default PRT at 10mA against the internal 1 $\Omega$  reference on the 13 $\Omega$  range on channel 1. The command to adjust the value assigned to the 1 $\Omega$  internal reference is:

`CAL:REF201 R1`

Where *R1* is the value calculated for the 1 $\Omega$  internal reference.

### 7.2.7 Calibrating Voltage Zeros

Short out the 4 measurement terminals on all 3 channels using a piece of un-insulated copper wire (use pure copper wire to avoid generating unwanted thermal EMFs) for each channel:

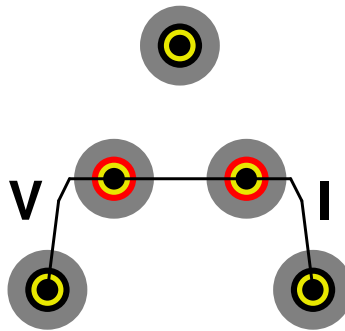

Type in the following commands to remove the zero/offset correction for all three channels:

`CAL:OFFS1 0`  
`CAL:OFFS2 0`  
`CAL:OFFS3 0`

Configure the microK to measure a Default Thermocouple on the 0.125V range with units of Volts on all 3 channels. Use 1 sample per reading and 100 readings in the rolling statistics (see section 3.6). Select the *Multi* tab and clear the statistics for all 3 channels. After the microK has collected at least 100 readings (shown as *Mean of last...* in the *Multi* tab, record the *Mean* for each channel and check that the standard deviation (*S.D.*) is less than 0.000000050 (0.05 $\mu$ V).

Now adjust the zero offsets using the commands:

CAL:OFFS1 *offset1*  
CAL:OFFS2 *offset2*  
CAL:OFFS3 *offset3*

Where *offsetX* is the zero offset measured for channel X. The value entered for each channel can be read back using CAL:OFFSX? (for channel X). Re-check the zero offsets for all three channels (see section 7.1.3.1).

## 7.2.8 Calibrating Voltage Span

Connect a stable, low noise voltage source with a nominal value of 50mV to channel 1 of the microK using low thermal EMF wire and connectors (copper or an alloy such as tellurium–copper that has a high copper content and low thermal EMF to pure copper. Brass connectors must NOT be used):

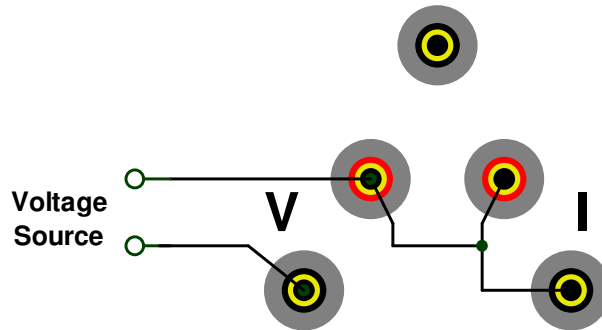

Configure the microK to measure a Default Thermocouple on the 0.125V range with units of Volts. Use 1 sample per reading and 100 readings in the rolling statistics (see section 3.6). Select the *Single* tab and clear the statistics. After the microK has collected at least 100 readings (shown as *Mean of last...* in the *Single* tab, record the *Mean* value and check that the standard deviation (*S.D.*) is less than 0.000000050V (0.05μV).

Calculate the require gain from:

$$gain = \frac{actual\ value}{measured\ value}$$

Now apply the new gain by typing the command:

CAL:GAIN X40,POS,*gain*

The value entered can be read back using `CAL:GAIN? X40,POS`

Repeat the procedure with the voltage source set to -50mV. Apply the new negative polarity gain by typing in the command:

`CAL:GAIN X40,NEG,gain`

The value entered can be read back using `CAL:GAIN? X40,NEG`

## 8 RS232 Interface

The microK is equipped with an RS232 interface. This can be used to control the microK and perform calibration and diagnostic functions. The command set uses the SCPI (Standard Commands for Programmable Instruments) protocol (see section 10 for details).

### 8.1 Establishing an RS232 Connection

The RS232 connector is located on the rear of your microK (see section 1.4). The connector is a 9-way (male) D-type configured as a standard DTE device:

Pin	Name	Function
1	CD	carrier detect (not connected)
2	RD	receive data
3	TD	transmit data
4	DTR	data terminal ready (fixed high)
5	SG	signal ground
6	DSR	data set ready (not connected)
7	RTS	request to send
8	CTS	clear to send
9	-	not used (not connected)
Shell	FG	frame ground (screen)

Connect your microK to a PC using a standard null-modem cable:

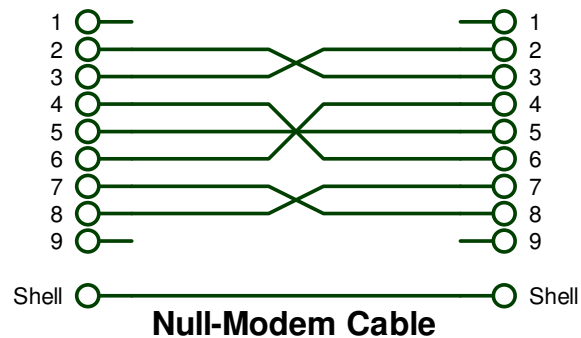

The format for the RS232 interface is as follows:

Baud Rate	9,600
Start Bits	1
Stop Bits	1
Parity Bit	none

The microK has a 256-byte circular receive buffer. If the buffer becomes full, it de-asserts RTS (connected to CTS on your PC through the null-modem cable) to prevent further data being sent. If the PC continues to send data this will be ignored (lost) until the microK has had time to make space in the buffer by processing commands. The microK does not use its CTS to control data it transmits.

You can use Hyperterminal (or another terminal emulator) to communicate with the microK via the RS232 connection. Hyperterminal is part of the standard Windows installation, usually located in the Accessories\Communications folder. If you have installed a minimum (laptop) or custom configuration (without this component) for your Windows operating system, you may need to install Hyperterminal from your original Windows media.

Start Hyperterminal to setup a new connection. Type in a name for the connection (such as microK) and select an icon. In the next window, select the PC's COM port to which you have connected your microK from the *Connect using* drop-down list and click OK. In the next window, enter the data format for the microK's RS232 interface:

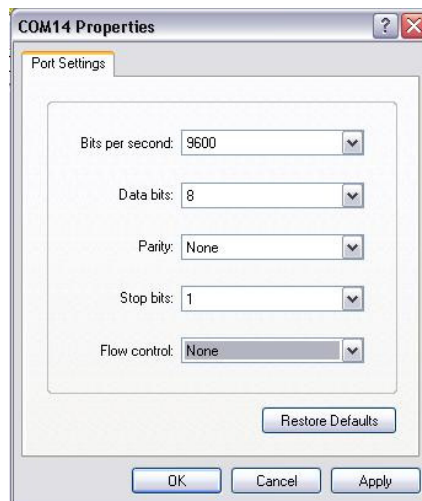

Click OK to open a Hyperterminal session with the microK. Now save (using File:Save As) the Hyperterminal connection so that in future you only have to click on this icon to open an RS232 connection with your microK.

Type `*IDN?` into Hyperterminal (terminate the command by pressing the carriage return or Enter keys), the microK should then respond with a string in the form:

Isothermal Technology, microK 400,10-P190,firmware version 3.17

This confirms that you have successfully established an RS232 connection with your microK.

## 9 GPIB

The microK is equipped with an IEEE-488 GPIB (General Purpose Interface Bus) port. This can be used to control the microK and perform calibration and diagnostic functions. The command set uses the SCPI (Standard Commands for Programmable Instruments) protocol (see section 10 for details).

The GPIB connector is located on the rear of your microK (see section 1.4). The connector is the standard IEEE-488 connector (24-way):

<b>Pin</b>	<b>Name</b>	<b>Function</b>	<b>Pin</b>	<b>Name</b>	<b>Function</b>
1	DIO1	Data Input/Output bit	13	DIO5	Data Input/Output bit
2	DIO2	Data Input/Output bit	14	DIO6	Data Input/Output bit
3	DIO3	Data Input/Output bit	15	DIO7	Data Input/Output bit
4	DIO4	Data Input/Output bit	16	DIO8	Data Input/Output bit
5	#EOI	End or Identify	17	#REN	Remote Enable
6	#DAV	Data Valid	18	GND	Ground (paired with #DAV)
7	NRFD	Not Ready for Data	19	GND	Ground (paired with NRFD)
8	NDAC	Not Data Accepted	20	GND	Ground (paired with NDAC)
9	#IFC	Interface Clear	21	GND	Ground (paired with #IFC)
10	#SRQ	Service Request	22	GND	Ground (paired with #SRQ)
11	#ATN	Attention	23	GND	Ground (paired with #ATN)
12	GND	Shield	24	GND	Logic Ground
Shell	-	Frame Ground (cable screen)			

Unlike the RS232 interface (which is full duplex) the GPIB is inherently half-duplex (data can only be transferred between the microK and the GPIB Controller in one direction at any given time, this direction being determined by the controller). If a response is expected from the microK, the GPIB Controller must address the microK as a Talker in order that it can transmit this information. The microK will try to send information on the GPIB for 2s, after which time it will abandon attempts to respond and revert to being a Listener in order to receive further commands on the GPIB. This 2s window will start as soon as the microK is ready to respond. There will be a delay from receiving the command to attempting to respond depending on the command (requesting data involves a short delay but requesting a measurement may take up to 2s) and whether the microK is busy processing other commands (if measurements are being requested via the front panel operator interface or via the RS232 interface).

The microK has a 254-byte receive buffer. If the command exceeds this length it will be truncated.

### **9.1 GPIB Address**

The microK behaves as a GPIB Peripheral and can have an address in the range 1 to 30 (inclusive). The factory default address is 10, but this can be changed pressing *Port Settings* in the Instrument tab (see section 3.7.7):

### **9.2 Establishing a GPIB Connection**

Connect your microK to a GPIB Controller using a standard (straight through) GPIB cable. Send *\*IDN?* to the GPIB address of the microK terminated with a Line Feed (see section 10.1 for acceptable terminators), the microK should then respond with a string in the form:

Isothermal Technology, microK 100,10-P190,firmware version 3.17

This confirms that you have successfully established a GPIB connection with your microK.

## **10 SCPI Command Set**

The command format and protocol used by the microK is based on the SCPI (Standard Commands for Programmable Instruments) standard. This was developed to provide a consistent command language for all types of programmable instruments. The objective was to reduce the development time required by users of these instruments by providing a consistent programming environment through the use of defined messages, instrument responses and data formats. Further information on SCPI can be obtained from the SCPI Consortium (<http://www.scpiconsortium.org>).

### **10.1 Command Terminators**

SCPI commands are ASCII (American Standard Code for Information Interchange) character strings. If sent to the microK's RS232 interface, these should be terminated with a Carriage Return character (ASCII character 13). Responses from the microK on the RS232 interface are always terminated by a Carriage Return character.

If commands are sent to the microK's GPIB port, they can be terminated by a Line Feed character (ASCII 10), Carriage Return character (ASCII 13), EOI condition (by pulling the #EOI line low during the last character of the ASCII string) or any combination of these. Responses from the microK on the GPIB interface are always terminated by a Line Feed character (the microK does not assert EOI at the end of a response).

### **10.2 SCPI Command Structure**

Commands are arranged in a hierarchical tree, similar to directory trees used in personal computers. SCPI uses a defined notation to represent the command tree structure. Each node in the tree structure is a command keyword with keywords being separated by colons (:). To simplify the description of the SCPI commands, the notation represents levels in the tree using horizontal indentations with the root node being the left most column. For example, the microK includes the following command structure:

```

SENSe
  :FUNCTION
  :CHANNEL
  :FREsistance
    :REFerence
    :REFerence?
    :RANGe
    :RANGe?
READ?
CALibrate
  :CURRent
  :OFFSet
  :OFFSet?

```

A valid command is formed by following the tree structure from a root node until a node is reached with no further nodes below it, for example in the above command tree we may use:

```
SENSe:FRESistance:REFerence
```

Keywords can be shortened to the first four letters (or 3 if the last letter is a vowel). To indicate this, the notation uses upper-case to indicate required letters and lower-case to indicate optional letters (NB: all commands are case-insensitive). For example, valid forms of the above command include:

```

Sense:Fresistance:Reference
SENS:FRES:REF
Sense:fresistance:REF

```

To shorten the commands, default (optional) keywords are enclosed in square brackets and may be omitted. For example, in the case of the command:

```
MEASure[:SCALAr]:VOLTage:[DC]?
```

Valid forms of this command include:

```

MEAS:VOLT?
MEASURE:SCALAR:VOLTAGE:DC?

```

### 10.2.1 SCPI Numeric Suffices

In order to support multiple input channels, commands can include numeric suffices. These are represented by a hash (#) in the command notation, for example:

```
MEASure:VOLTage:<channel#>?
```

In addition to the 3 input channels on the front panel (which are assigned the suffices 1, 2 and 3) the internal reference resistors are specified using numeric suffices as follows:

channel#	Internal reference resistor
201	1 $\Omega$
202	10 $\Omega$
203	25 $\Omega$
204	100 $\Omega$
205	400 $\Omega$

In order to measure the voltage on channel 3, the command used would be:

```
MEAS:VOLT3?
```

### 10.2.2 Parameters

If a command requires parameter(s), these follow the command and are separated from it by a space. If more than one parameter is required, each parameter is separated by a comma (.). For example, the command to measure a four-terminal resistance on channel 1 against a reference resistor on channel 2 using the 100 ohm range and a sense current of 1mA would be:

```
MEAS:FRES1:REF2? 100,1
```

### 10.2.3 Units

Numeric parameters may optionally include units. The standard multiplying prefixes may also be used to indicate decimal multiples or fractions. For example, the following are all equivalent.

```
CURRENT 0.001A  
CURRENT 1ma
```

CURRENT 1000UA  
CURRENT 1

The following prefixes are available:

<i>prefix</i>	<i>name</i>	<i>factor</i>
N or n	nano	$10^{-9}$
U or u	micro	$10^{-6}$
M or m	milli	$10^{-3}$
K or k	kilo	$10^{+3}$
MA or ma	mega	$10^{+6}$

## 10.3 Making Measurements using SCPI Commands

The microK's measurement system is controlled by a microprocessor connected to the rear panel RS232 interface and a GPIB port. The measurement system can be controlled by SCPI commands from either of these. The firmware makes no distinction between commands received on the RS232 interface and those from the GPIB and will process these in the order in which they are detected. If a response is expected, it will always be sent on the interface (RS232 or GPIB) on which the corresponding command was sent.

There is no direct interference between measurements made using the front panel operator interface and measurements requested using SCPI commands. However, measurements take some time to complete so there may be a delay in responses to SCPI commands if measurements are being made via the front panel operator interface. To avoid unnecessary delays to responses to SCPI commands, you can stop all measurements requested via the front panel operator interface. The easiest way to do this is to restart the microK and then not press *Resume* in the opening window. The main application that provides the user interface will then not start and no measurements will be requested.

### 10.3.1 Measuring Resistance using SCPI Commands

In order to measure the resistance of a PRT, you need to:

- ⌚ set the microK to measure resistance
- ⌚ set the sense current
- ⌚ select the measurement range
- ⌚ select the measurement channel
- ⌚ select the reference channel
- ⌚ make the measurement

If you want to measure a 25.5Ω SPRT up to a maximum resistance of 30Ω against the internal 100Ω reference, the maximum resistance that the measurement system sees is 100Ω. To make this measurement using a 1mA sense current, you can use the following command sequence:

```
SENS:FUNC FRES  
CURR 1  
SENS:FRES:RANG 100,1
```

```
SENS:CHAN 1
SENS:FRES:REF 204
READ?
```

The microK will then report the measured resistance, for example “2.5250637862E001”.

The following command performs the same measurement:

```
MEAS:FRES1:REF204? 100,1
```

### 10.3.2 Measuring Voltage using SCPI Commands

In order to measure the voltage from a thermocouple, you need to:

- ⌵ set the microK to measure voltage
- ⌵ select the measurement range
- ⌵ select the measurement channel
- ⌵ make the measurement

If you want to measure the voltage from a thermocouple, you should always use the most sensitive voltage range (0.125V) since this provides the lowest uncertainty and no thermocouple output will exceed this range. You can use the following command sequence:

```
SENS:FUNC VOLT
SENS:VOLT:RANG 0.1
SENS:CHAN 1
READ?
```

The microK will then report the measured voltage, for example “1.12999999E-007”.

The following command performs the same measurement:

```
MEAS:VOLT1? 0.1
```

## 10.4 SCPI Commands

The microK supports the following commands:

```
*IDN?
*RST
SENSe
    :FUNction[:ON]           <function>
    :FUNction[:ON]?
    :CHANnel                 <channel>
    :CHANnel?
    :VOLTage[:DC]
        :RANGe[:UPPer]      <voltage range>
        :RANGe[:UPPer]?
    :FRESistance
        :REFerence          <reference channel>
        :REFerence?
        :RANGe[:UPPer]      <resistance range>, <current>
        :RANGe[:UPPer]?
    :RATio
        :REFerence          <denominator channel>
        :REFerence?
        :RANGe[:UPPer]      <resistance range>, <current>
        :RANGe[:UPPer]?
INITiate[:IMMediate][:ALL]
FETCh[:SCALar]?
READ[:SCALar]?
READ<channel#>?
MEASure[:SCALar]
    :VOLTage[:DC]<channel#>?  <voltage range>
    :FRESistance<channel#>
        :REFerence<reference#>?  <resistance range>, <current>
    :RATio<channel#>
        :REFerence<reference#>?  <resistance range>, <current>
[:SOURce]:CURRent           <current>
TEST
    :CURRent                 <current>
CALibrate
    :CURRent                 <actual current>
    :REFerence<reference#>   <actual resistance>
    :REFerence<reference#>?
    :OFFSet<channel#>       <offset>
    :OFFSet<channel#>?
    :GAIN                    <gain>, <polarity>, <adjustment>
    :GAIN?                   <gain>, <polarity>
    :PASSword                <old password>, <password>, <password>
    :UNLock                  <password>
    :LOCK
```

A detailed description of each command follows:

#### 10.4.1 Command: \*IDN?

Format: \*IDN?

Reports information on the microK in 4 comma separated fields:

- ⌋ manufacturer
- ⌋ model
- ⌋ serial number
- ⌋ firmware version

Example: for a microK 400 with serial number 261067/1 using firmware version 1.20, the microK responds to \*IDN? with:

Isothermal Technology,microK 400,261067/1,firmware version 1.20

#### 10.4.2 Command: \*RST

Format: \*RST

Performs a reset (equivalent to a power-on reset) of the measurement system firmware.

#### 10.4.3 Command: SENSE:FUNCTION

Format: SENSE:FUNCTION *<function>*

Selects the measurement function. The parameter *<function>* must be one of the following valid SCPI parameters:

- ⌋ VOLTage[:DC]
- ⌋ FRESistance
- ⌋ RATio

Example: to set the microK to measure ratio, use: [SENS:FUNC RAT](#)

#### 10.4.4 Command: SENSE:FUNCTION?

Format: SENSE:FUNCTION?

Reports the current measurement function.

Example: a microK set to measure voltage will respond to [SENS:FUNC?](#) with “VOLTAGE”.

#### 10.4.5 Command: SENSE:CHANnel

Format: SENSE:CHANnel *<channel>*

Selects the channel for the next measurement. The channel is not actually selected until a measurement is started using with either the INITiate or READ? commands.

Example: to select channel 2 for the next measurement, use: [SENS:CHAN 2](#)

#### 10.4.6 Command: SENSE:CHANnel?

Format: SENSE:CHANnel?

Reports the channel selected for the next measurement.

Example: a microK set to measure channel 1 on the next measurement will respond to [SENS:CHAN?](#) with: “1”.

#### 10.4.7 Command: SENSE:VOLTage:RANGe

Format: SENSE[:DC]:VOLTage:RANGe[:UPPER] *<voltage range>*

Sets the range for the next voltage measurement. There are 3 voltage ranges available in the microK:

⌚ 0 – 0.125V

⌚ 0 - 0.5V

⌚ 0 - 2.5V

If you enter a numeric value other than one of the above, the microK will round the value up to the next available range. Always use the most sensitive range possible to minimise uncertainties. Therefore, when measuring thermocouples always use the 0.125V range.

Example: to set the microK to measure a thermocouple that has a maximum output voltage of 20mV, use: [SENS:VOLT:RANG 20mV](#). This will set the microK to the 125mV range.

#### 10.4.8 Command: SENSE:VOLTage:RANGe?

Format: SENSE[:DC]:VOLTage:RANGe[:UPPER]?

Reports the range for the next voltage measurement (0.125, 0.5 or 2.5)

Example: a microK that has had its voltage range set using the command shown in section 10.4.7) would respond to the command: `SENS:VOLT:RANG?` with: “0.125”.

#### 10.4.9 Command: SENSE:FRESistance:REFerence

Format: SENSE:FRESistance:REFerence <reference channel>

Selects the reference channel for the next resistance measurement made. The channel is not actually selected until a measurement is started using with either the INITiate or READ? commands.

Example: to select channel 204 (internal 100 ohm resistor) as the reference channel for the next resistance measurement, use: `SENS:FRES:REF 204`

#### 10.4.10 Command: SENSE:FRESistance:REFerence?

Format: SENSE:FRESistance:REFerence?

Reports the channel selected as the reference channel for the next resistance measurement.

Example: a microK set to use channel 204 as the reference in the next resistance measurement will respond to the command `SENS:FRES:REF?` with: “204”.

#### 10.4.11 Command: SENSE:FRESistance:RANGe

Format: SENSE:FRESistance:RANGe[:UPPer] <resistance range>,<current>

Sets the range for the next resistance measurement. The range is determined by the voltage range of the measurement system (0.125, 0.5 or 2.5V) and depends on the sense current used. The *current* parameter is the current you intend to use in the measurement, this may not be the same as the present value of sense current that is set with the CURRent command. The 3 resistance ranges available with the microK are:

- ⌋ *resistance range = 0.125V / current*
- ⌋ *resistance range = 0.5V / current*
- ⌋ *resistance range = 2.5V / current*

The resistance range specified should be the higher of the maximum PRT resistance and reference resistor since the measurement system has to measure the signal across both to determine the resistance of the device under test.

Example: to set the microK to measure a PRT that has a maximum resistance of 130Ω (using a 100Ω reference resistor) with a 1mA sense current, use:

[SENS:FRES:RANG 130,1](#). This will set the microK to the middle range.

#### **10.4.12 Command: SENSE:FRESistance:RANGe?**

Format: SENSE:FRESistance:RANGe[:UPPer]?

Reports the range for the next resistance measurement at the present sense current (set using the CURRent command). The current used to calculate the range may be different from that specified when the range was set using the SENSE:FRESistance:RANGe command. The reported range is the actual range for the measurement system at the present sense current.

Example: a microK that has had its resistance range set using the command shown in section 10.4.11 but has its sense current set to 10mA would respond to the command: [SENS:FRES:RANG?](#) with: “50.000000”.

#### **10.4.13 Command: SENSE:RATio:REFerence**

Format: SENSE:RATio:REFerence <reference channel>

Selects the reference channel for the next resistance ratio measurement made. The channel is not actually selected until a measurement is started using with either the INITiate or READ? commands.

Example: to select channel 2 as the reference channel for the next resistance ratio measurement, use: [SENS:RAT:REF 2](#)

#### **10.4.14 Command: SENSE:RATio:REFerence?**

Format: SENSE:RATio:REFerence?

Reports the channel selected as the reference channel for the next resistance ratio measurement.

Example: a microK set to use channel 2 as the reference in the next resistance ratio measurement will respond to the command `SENS:RAT:REF?` with: “2”.

#### 10.4.15 Command: `SENSe:RATio:RANGe`

Format: `SENSe:RATio:RANGe[:UPPer]` *<resistance range>*,*<current>*

Sets the range for the next resistance ratio measurement. The range is determined by the voltage range of the measurement system (0.125, 0.5 or 2.5V) and depends on the sense current used. The *current* parameter is the current you intend to use in the measurement, this may not be the same as the present value of sense current that is set with the `CURRent` command. The 3 resistance ranges available with the microK are:

- ‡ *resistance range* =  $0.125V / current$
- ‡ *resistance range* =  $0.5V / current$
- ‡ *resistance range* =  $2.5V / current$

The resistance range specified should be the higher of the maximum PRT resistance and reference resistor since the measurement system has to measure the signal across both to determine their ratio.

Example: to set the microK to measure the resistance ratio of a PRT that has a maximum resistance of 130Ω (with a 100Ω reference resistor) with a 1mA sense current, use: `SENS:RAT:RANG 130,1`. This will set the microK to the middle range.

#### 10.4.16 Command: `SENSe:RATio:RANGe?`

Format: `SENSe:RATio:RANGe[:UPPer]?`

Reports the range for the next resistance ratio measurement at the present sense current (set using the `CURRent` command). The current used to calculate the range may be different from that specified when the range was set using the `SENSe:RATio:RANGe` command. The reported range is the actual range for the measurement system at the present sense current.

Example: a microK that has had its resistance ratio range set using the command shown in section 10.4.15 but has its sense current set to 10mA would respond to the command: `SENS:RAT:RANG?` with: “50.000000”.

#### **10.4.17 Command: INITiate**

Format: `INITiate[:IMMEDIATE][:ALL]`

Initiates a measurement using the conditions defined by previous `SENSe` commands. The measurement is made immediately, but not reported.

Example: to initiate a voltage measurement that has been defined with `SENSe` commands (such as `SENS:CHAN 1`, `SENS:FUNC volt` and `SENS:VOLT:RANG 0.1`) use: `INIT`

#### **10.4.18 Command: FETCh?**

Format: `FETCh[:SCALar]?`

Reports the result of the last measurement made.

Example: a microK that has made a measurement on a short circuit connected to channel 1 using the commands shown in the example in section 10.4.17 will respond to `FETC?` with something similar to : “1.70000000E-008”.

#### **10.4.19 Command: READ?**

Format: `READ[:SCALar]?`

Initiates and reports a measurement using the conditions defined by previous `SENSe` commands. This is equivalent to `INIT` followed by `FETCh?`

Example: a microK that is connected to a short circuit on channel 1 and has been configured to make a voltage measurement using `SENSe` commands (such as `SENS:CHAN 1`, `SENS:FUNC volt` and `SENS:VOLT:RANG 0.1`) will respond to `READ?` with something similar to : “1.70000000E-008”.

#### **10.4.20 Command: READ#?**

Format: `READ<channel#>?`

Reports the next measurement and units on <channel#> made using the front panel operator interface. It is the only command that allows the user to access results in temperature units. Unlike other commands, where it is recommended that the operator interface is left dormant (Resume not pressed to speed up measurements) the operator interface **MUST** be running (measurements being made) in order for this command to function.

Example: a user who is making temperature measurements on channel 1 using an SPRT (see section 2.1) can read the temperature measurements by sending **READ1?** The microK will respond with something similar to “1.23456789,C”.

The units are reported using:

X = Ratio  
R = Ohms  
V = Volts  
K = Kelvin  
C = Celsius  
F = Fahrenheit

If the requested channel does not exist or is not enabled, the microK will respond with “not enabled,X”.

#### **10.4.21 Command: MEASure:VOLTage?**

Format: MEASure[:SCALar]:VOLTage[:DC]<channel#>? <voltage range>

Initiates and reports a voltage measurement on <channel#> using the voltage range specified (note that there is no gap between the command and the channel number as this command makes use of the numeric suffices feature of SCPI described in section 10.2.1). This command is equivalent to **SENS:FUNC volt**, **SENS:CHAN <channel>**, **SENS:VOLT:RANG <voltage range>** and **READ?** The voltage range specified is rounded up to the nearest available range.

Example: to initiate a voltage measurement on channel 3 using the 0.125V range use: **MEAS:VOLT3 0.125**

#### **10.4.22 Command: MEASure:FRES:REF?**

Format: MEASure[:SCALar]:FRESistance<channel#>:REFerence<reference#>?

<resistance range>,<current>

Initiates and reports a resistance measurement on <channel#> against a reference on channel <reference#> using <resistance range> with sense <current> (note that there is no gap between the command and the channel numbers as this command makes use of the numeric suffices feature of SCPI described in section 10.2.1). This command is equivalent to **SENS:FUNC fres**, **SENS:FRES:REF <reference#>**, **SENS:FRES:RANG <resistance range>**, **<current>**, **SENS:CHAN <channel>** and **READ?**

Example: to set the microK to measure a PRT on channel 1 that has a maximum resistance of 130Ω using the internal 100Ω reference resistor with a 1mA sense current, use: **MEAS:FRES1:REF204? 130,1**

#### **10.4.23 Command: MEASure:RAT:REF?**

Format: **MEASure[:SCALar]:RATio<channel#>:REFerence<reference#>?**  
**<resistance range>**, **<current>**

Initiates and reports a resistance ratio measurement on <channel#> against a reference on channel <reference#> using <resistance range> with sense <current> (note that there is no gap between the command and the channel numbers as this command makes use of the numeric suffices feature of SCPI described in section 10.2.1). This command is equivalent **SENS:FUNC rat**, **SENS:RAT:REF <reference#>**, **SENS:RAT:RANG <resistance range>**, **<current>**, **SENS:CHAN <channel>** and **READ?**

Example: to set the microK to measure the resistance ratio of a PRT on channel 1 that has a maximum resistance of 130Ω against a 100Ω reference resistor on channel 2 with a 1mA sense current, use: **MEAS:RAT1:REF2? 130,1**

#### **10.4.24 Command: CURRent**

Format: **[SOURce]:CURRent <current>**

Set the sense current for the next resistance or ratio measurement to <current>. The current is not changed until a measurement is started using with either the **INITiate** or **READ?** commands.

Example: to set the sense current for the next resistance measurement to 2mA  
use: [CURR 2](#)

#### **10.4.25 Command: TEST:CURRent**

Format: TEST:CURRent *<current>*

Immediately sets the sense current on channel 1 to *<current>*.

Example: to set the sense current on channel 1 to 5mA use: [TEST:CURR 5](#)

#### **10.4.26 Command: CALibrate:CURRent**

Format: CALibrate:CURRent *<actual current>*

This command is used after using the [TEST:CURR 1](#) command and measuring the current from channel 1 (see section 7.2.1). It uses the actual current entered to adjust the master current source the correct current.

Example: the current from channel 1 after using the command [TEST:CURR 1](#) was measured as 1.00123. To adjust the master current source correctly use:  
[CAL:CURR 1.00123](#)

#### **10.4.27 Command: CALibrate:REFerence**

Format: CALibrate:REFerence<reference#> *<actual resistance>*

Used to calibrate the internal *<reference#>* standard by assigning a new *<actual resistance>* to it. The channel numbers (numeric suffices) used for the internal resistor are given in section 10.2.1. The calibrated value is stored as a floating point number and will therefore be subject to some rounding (less than 0.12ppm of value)

Example: if the value of the internal 100Ω reference has been measured as 100.00123, the new value can be assigned to it using: [CAL:REF204 100.00123](#)

#### **10.4.28 Command: CALibrate:REFerence?**

Format: CALibrate:REFerence<reference#>?

Used to report the calibrated value of the internal <reference#> resistor (used by the microK to calculate resistance).

Example: a microK with an internal 25Ω reference having a calibrated value of 25.01234 will respond to [CAL:REF203](#) with “25.01234”

#### **10.4.29 Command: CALibrate:OFFSet**

Format: CALibrate:OFFSet<channel#> <offset>

Adjusts the voltage offset for <channel#> used when making voltage measurements. The offset range is ±2μV, attempts to apply an offset greater than this will be ignored. The offset is stored as a floating point number and will therefore be subject to some rounding (less than 0.12ppm of value)

Example: to subtract an offset of 0.123μV from voltages measured on channel 3 use: [CAL:OFFS3 0.123](#)

#### **10.4.30 Command: CALibrate:OFFSet?**

Format: CALibrate:OFFSet<channel#>?

Reports the offset subtracted from voltage measurements on <channel#>

Example: a microK that has been calibrated to have a 0.123μV offset subtracted from voltage measurement on channel 2 will respond to [CAL:OFFS2?](#) with “1.23E-07”.

#### **10.4.31 Command: CALibrate:GAIN**

Format: CALibrate:GAIN <gain>,<polarity>,<adjustment>

Adjusts the value of <gain> for <polarity> by the factor <adjustment>. The parameter <gain> must be one of three strings defining the nominal gain of the microK pre-amplifier:

- ⌵ X2
- ⌵ X10
- ⌵ X40

The parameter <polarity> must be either POSitive or NEGative.

The gain adjustment is stored as a floating point number and will therefore be subject to some rounding (less than 0.12ppm of value)

Example: for a microK that has been found to have a voltage gain for positive readings on its x40 range that is low by a factor of 1.000123 (see section 7.2.8), the gain can be corrected using: [CAL:GAIN X40,POS,1.000123](#)

#### **10.4.32 Command: CALibrate:GAIN?**

Format: CALibrate:GAIN? *<gain>*,*<polarity>*

Reports the total calibration adjustment applied to the voltage *<gain>* range. The parameter *<gain>* must be one of three strings defining the nominal gain of the microK pre-amplifier:

- ‡ X2
- ‡ X10
- ‡ X40

The parameter *<polarity>* must be either POSitive or NEGative.

Example: a microk that has had a number of adjustments to its nominal x40 gain causing a total ratio adjustment of 1.000123 for positive readings will respond to [CAL:GAIN? X40,POS](#) with “1.000123”

#### **10.4.33 Command: CALibrate:PASSword**

Format: CALibrate:PASSword *<old password>*,*<password>*,*<password>*

Changes the password used to lock (protect) the calibration of the microK’s measurement system. This is initially set to “1234”, but should be changed before using the microK for any critical or traceable measurement or calibration work. The new password must be at least 4 characters in length and must be typed in identically twice in order to effect the change.

Example: to change the password from 1234 to ABCD use: [CAL:PASS 1234,ABCD,ABCD](#)

#### **10.4.34 Command: CALibrate:UNLock**

Format: CALibrate:UNLock *<password>*

Unlocks the microK to allow calibration adjustment. The microK always powers up in the locked state. Calibration can be re-locked by re-powering the microK or using [CAL:LOCK](#) (see section 10.4.35).

Example: to unlock (enable) the calibration adjustment on a microK with the default password (“1234”), use: [CAL:UNL 1234](#)

### **10.4.35 Command: CALibrate:LOCK**

Format: CALibrate:LOCK

Locks the microK to prevent calibration adjustment.

Example: to lock the calibration of a microK after adjustment, use: [CAL:LOCK](#)

## 11 Specification

<b>Ranges</b>	Resistance Thermometers: 0 $\Omega$ to 500k $\Omega$ Thermocouples: $\pm$ 125mV
<b>Accuracy – PRTs</b>	$\mu$ K400: 0.4ppm maximum over whole range for SPRT with $R_0 \geq 2.5\Omega$ (equivalent to 0.1mK at 0 $^{\circ}$ C, or 0.4mK over full range) 1ppm maximum over whole range for SPRT with $R_0=0.25\Omega$ $\mu$ K800: 0.8ppm maximum over whole range for SPRT with $R_0 \geq 2.5\Omega$ (equivalent to 0.2mK at 0 $^{\circ}$ C, or 0.8mK over full range) 2ppm maximum over whole range for SPRT with $R_0=0.25\Omega$
<b>Accuracy – Thermocouples</b>	Voltage uncertainty: 250nV (between 0 and 20mV) equivalent to 0.01 $^{\circ}$ C for Gold-Platinum thermocouple at 1000 $^{\circ}$ C
<b>Resolution</b>	Resistance: 0.01ppm of range Voltage: 2nV (125mV range)
<b>Stability</b>	Resistance (excluding resistance standard): 0 (note1) Voltage: 3ppm/year
<b>Measurement Time</b>	Resistance: < 2s (1s using the RS232 or GPIB interfaces) Voltage: < 1s (0.5s using the RS232 or GPIB interfaces)
<b>Temperature Conversions</b>	<u>PRTs</u> : ITS-90, Callendar-van Dusen <u>Thermocouples</u> : IEC584-1 1995 (B,E,J,K,N,R,S,T), L and gold-platinum <u>Thermistors</u> : Steinhart-Hart
<b>Sensor Current</b>	0-10mA in 3 ranges: 0.1mA $\pm$ 0.4% of value, $\pm$ 70nA, resolution 28nA 1mA $\pm$ 0.4% of value, $\pm$ 0.7 $\mu$ A, resolution 280nA 10mA $\pm$ 0.4% of value, $\pm$ 7 $\mu$ A, resolution 2.8 $\mu$ A

<b>Keep-Warm Current</b>	0-10mA $\pm 0.4\%$ of value, $\pm 7\mu\text{A}$ , resolution 2.8 $\mu\text{A}$
<b>Cable Length</b>	<30m (maximum 10 $\Omega$ per core or 10nF shunt capacitance)
<b>Internal Standard Resistors</b>	1 $\Omega$ $\pm 0.1\%$ TCR = $\pm 0.6\text{ppm}/^\circ\text{C}$ typical, stability $\pm 5\text{ppm}/\text{year}$ 10 $\Omega$ $\pm 0.1\%$ TCR = $\pm 0.6\text{ppm}/^\circ\text{C}$ typical, stability = $\pm 5\text{ppm}/\text{year}$ 25, 100, 400 $\Omega$ $\pm 0.1\%$ TCR = $\pm 0.3\text{ppm}/^\circ\text{C}$ typical, stability = $\pm 5\text{ppm}/\text{year}$
<b>Input Connectors</b>	“Cable Pod” connectors for: 4mm plugs, spades or bare wires Contact material: gold plated tellurium copper
<b>Interfaces</b>	RS232 (9,600 baud) GPIB USB (1.1) – host
<b>Display</b>	163mm / 6.4” VGA (640 x 480) colour TFT LCD
<b>Operating Conditions</b>	15-30 $^\circ\text{C}$ / 50-85 $^\circ\text{F}$ , 10-90% RH (for full specification) 0-40 $^\circ\text{C}$ / 32-105 $^\circ\text{F}$ , 0-99% RH (operational)
<b>Power</b>	88 – 264V (RMS), 47-63Hz (Universal) 20W maximum, 1.5A (RMS) maximum
<b>Size</b>	520mm x 166mm x 300mm / 20.5” x 6.6” x 11.9” (W x D x H)
<b>Weight</b>	12.4kg / 27lb

Notes:

1. The microK uses a ‘substitution technique’ in which the Device-Under-Test and the Reference are successively switched into the same position in the measuring circuit. This means that the stability of resistance ratio measurements is immeasurably small (see section 6.2)

## 12 Approvals

The microK has been independently verified as complying with the regulatory requirements of the EU and FCC for electromagnetic compatibility and safety (EU only).

### 12.1 CE Declaration



**European Community Electromagnetic Compatibility Directive (89/336)**  
**European Community Low Voltage Directive (93/68)**

The microK Precision Thermometry Bridge manufactured by Isothermal Technology Limited of Pine Grove, Southport, Merseyside, PR9 9AG, United Kingdom conforms to the requirements of the European Community Electromagnetic Compatibility Directive (89/336) and of the European Community Low Voltage Directive (93/68).

### 12.2 FCC Statement

This equipment has been tested and found to comply with the limits for a Class A digital device, pursuant to part 15 of the FCC Rules. These limits are designed to provide reasonable protection against harmful interference when the equipment is operated in a commercial environment. This equipment generates and can radiate radio frequency energy and, if not installed and used in accordance with the instruction manual, may cause harmful interference to radio communications. Operation of this equipment in a residential area may cause harmful interference, in which case the user will be required to correct the interference at his own expense. Changes or modifications to this equipment not expressly approved by Isothermal Technology could degrade EMC performance and void the user's authority to operate the equipment.

### **12.3 Standards Applied**

The following standards have been applied in assessing compatibility with the requirements for CE marking and for FCC compliance:

Conducted Emissions	EN61326:1997 & CFR47:2005
Radiated Emissions	EN61326:1997 & CFR47:2005
Conducted Immunity	EN61326:1997
Radiated Immunity	EN61326:1997
Electrical Fast Transients	EN61326:1997
Electrostatic Discharge	EN61326:1997
Surge	EN61326:1997
Voltage Dips & Interruptions	EN61326:1997
Harmonic Currents	EN61000-3-2:2000
Flicker	EN61000-3-3:1995
Electrical Safety	EN61010-1:2001